

Appendix B - Standard Construction Drawings

QLDC Land Development and Subdivision Code of Practice - 2020

Normative

TABLE OF CONTENTS

B1-1 Typical Combined Service Trench Detail
B1-2 Standard Pipe Embedment
B1-3 Typical Pipe Bedding & Backfill for Carriageways
B1-4 Typical Pipe Bedding & Backfill for Vehicle Crossings & non trafficable
B1-5 Manhole Detail A –Typical Plan view
B1-6 Manhole Details B
B1-7 Manhole Detail C
B1-8 Mini & Drop Manhole Detail
B1-9 PVC Inspection Chamber (Residential Only)
B1-10 Lateral Connections for two Properties
B1-11 Domestic Drainage (Shallow Connection) Detail
B1-12 Domestic Drainage (Deep Connection) Detail
B2-1 Fire Hydrant
B2-2 Typical Cast Iron Valve Box
B2-3 Typical Service Connection
B2-4 Sluice Valve Detail
B2-5 Typical Thrust Block Details
B2-6 Residential Fire System Connection with Potable Supply
B2-7 Commercial Fire System Connection with Potable Supply
B2-8 Water Supply with Bulk Flow Meter
B2-9 PRV Valve Chamber
B2-10 Water Sampling Point
B3-1 Private Pressure Sewer Main Connection to Sewer Lateral
B4-1 Inlet & outlet Structures
B4-2 Concrete Capping Detail
B4-3 Scruffy Dome Detail
B4-4 Soak Pit
B5-1 Dimensions of No-Exit Road Turning Areas
B5-2 Turning Areas for No-Exit Roads
B5-3 Parking Bay
B5-4 Subsoil drains - Roadside
B5-5 Typical Swale Detail
B5-6 Typical Swale Detail (when check dams required)
B5-7 Typical Check Dam Detail
B5-8 Kerbs and Dished Channels
B5-9 Typical sump to driveway or right of way

B5-10 Flat channel or Yard Sump – Private Only
B5-11 Road Sump Detail
B5-12 Different Grate Layouts
B5-13 Standard Back Entry Sump
B5-14 Double back-entry sump for road low points and alternative
B5-15 Traversable Grates for Precast Headwalls 255mm to 450mm Culverts
B5-16 Mountable Grates for Precast Headwalls 255mm to 450mm Culverts
B5-17 Berm Sump Detail
B5-18 Vehicle Crossing - Residential
B5-19 Vehicle Crossing – Commercial / Industrial
B5-20 Private Rural Access
B5-21 Non-Precast Headwall Detail
B5-22 Heavy Duty Footpath
B5-23 Footpath – Asphalt & Gritted Detail
B5-24 Pedestrian Crossing Detail
B6-1 Street Sign: Pole Mount
B7-1 CM – 001 Embedment & Trenchfill Arrangement
B7-2 CM – 002 Embedment & Trenchfill Arrangement
B7-3 CM - 003 Bulkheads & Trench stop Standard Details
B7-4 WS – 001 Typical Mains Construction – Reticulation Main Arrangements
B7-5 WS – 002 Typical Mains Construction – Distribution And Transfer Mains
B7-6 WS – 003 Property Services – Connection to an existing PVC Main
B7-7 WS – 005 Thrust and anchor blocks – Gate valves and vertical bends if required
B7-8 WW – 001 Pipelaying – Typical Arrangements
B7-9 WW – 002 Property connections – Buried interface method
B7-10 WW – 003 Maintenance shafts – Typical installation
B7-11 WW – 004 Maintenance shafts – MS and variable bend installations
B7-12 WW – 005 Maintenance shafts – TMS and connection installation

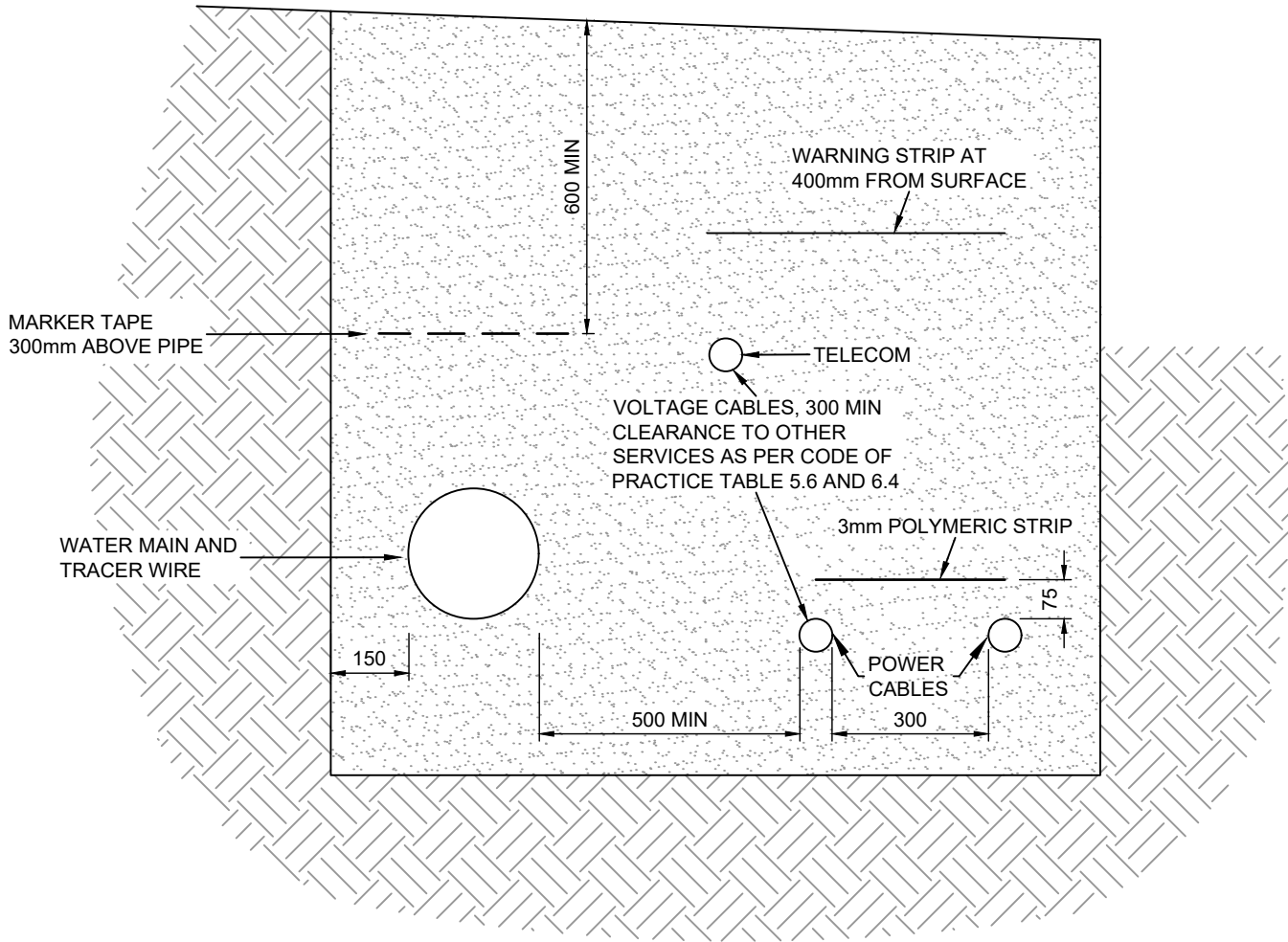

TRENCH DETAILS & UNDERGROUND UTILITIES IN VERGE

NOTE
SEPARATION FROM WATERMAIN DEFINED IN COP TABLE 6.4 (VARIES WITH PIPE SIZE)

MARKER TAPE 300mm
ABOVE PIPE INCLUDING
TRACERWIRE FOR PE PIPE

BED PIPING DIRECTLY ON IN
SITU SAND. ENSURE THAT PIPE
DOES NOT REST ON ITS JOINTS
BY OVER EXCAVATING AT JOINT.
REFER TO CM-001

'LO'

TRENCH FILL

PIPE EMBEDMENT

TRENCH IN SAND STRATA

MARKER TAPE 300mm
ABOVE PIPE INCLUDING
TRACERWIRE FOR PE PIPE

GEOTEXTILE
OVERLAY WHERE
REQUIRED (SEE
NOTE 7)

'LO'

TRENCH FILL

PIPE EMBEDMENT

GRANULAR
MATERIAL AS
SPECIFIED

'Lb' = 100-150
(SEE NOTE 6)

TRENCH FLOOR (SEE NOTE 5)

TYPE 3 SUPPORT

FOR FLEXIBLE AND RIGID PIPES (SEE NOTE 3)

FABRIC LAP
(SEE NOTE 8)

'LO'

TRENCH FILL

PIPE EMBEDMENT

GEOTEXTILE
FILTER FABRIC
(SEE NOTE 8)
WHERE REQUIRED

GRANULAR MATERIAL
AS SPECIFIED

TYPE 4 SUPPORT

WITH GEOTEXTILE FOR FLEXIBLE AND RIGID PIPES (SEE NOTE 3)

NOTES:

1. ALL DIMENSIONS IN MILLIMETRES
2. THIS DRAWING TO BE READ IN CONJUNCTION WITH CM-001
3. PIPE CLASSIFICATION
 - a. RIGID PIPES: VC, RC, STEEL AND CL
 - b. FLEXIBLE PIPES: PVC, GRP AND PE
4. PLACEMENT OF EMBEDMENT, TRENCH FILL AND COMPACTION TO MEET THE REQUIREMENTS OF DRAWINGS AND SPECIFICATION.
5. EXCAVATE OR COMPACT TRENCH FLOOR TO PROVIDE A FLAT FIRM BASE TO SUPPORT BEDDING MATERIAL AND MINIMISE PIPE SETTLEMENT. WHEN EXCAVATED, REPLACE WITH GRANULAR MATERIAL AS SPECIFIED FOR BEDDING OR ADOPT TYPE 1,2,3 OR 4 SUPPORT AS REQUIRED.
6. ENSURE BEDDING IS DEEP ENOUGH THAT PIPE JOINT PROJECTIONS (SOCKETS AND FLANGES) DO NOT TOUCH TRENCH FLOOR - SEE CM-001

7. TYPE 4 SUPPORT TO BE USED WHERE MIGRATORY NATIVE SOILS (SANDS AND CLAYS) ARE ENCOUNTERED ADJACENT TO THE EMBEDMENT ZONE AND SINGLE SIZED AGGREGATE IS USED.
8. GEOTEXTILE OVERLAY IS REQUIRED FOR COARSE AGGREGATE EMBEDMENT >5mm. LAY GEOTEXTILE FILTER FABRIC AGAINST TRENCH FLOOR AND WALLS SUCH THAT IT FULLY ENCASES THE EMBEDMENT
 - PRESS FILTER FABRIC INTO VOIDS BEFORE INSTALLING EMBEDMENT TO PREVENT FABRIC TEARING
 - PROVIDE A MINIMUM OF 250 OVERLAP AT ALL FILTER FABRIC JOINTS
9. IN SOME AREAS LOCAL PRACTICE MAY ALLOW USE OF SELECTED EXCAVATED MATERIAL AS PIPE EMBEDMENT.
10. IN UNSUITABLE GROUND CONDITIONS SPECIFIC DESIGN IS REQUIRED REFER TO WSA 03 & WSA 04 DRAWINGS FOR GUIDANCE.
11. CONCRETE PIPES SHOULD BE BASED ON FIGURES 11 TO 13 IN ASNZS 3725.

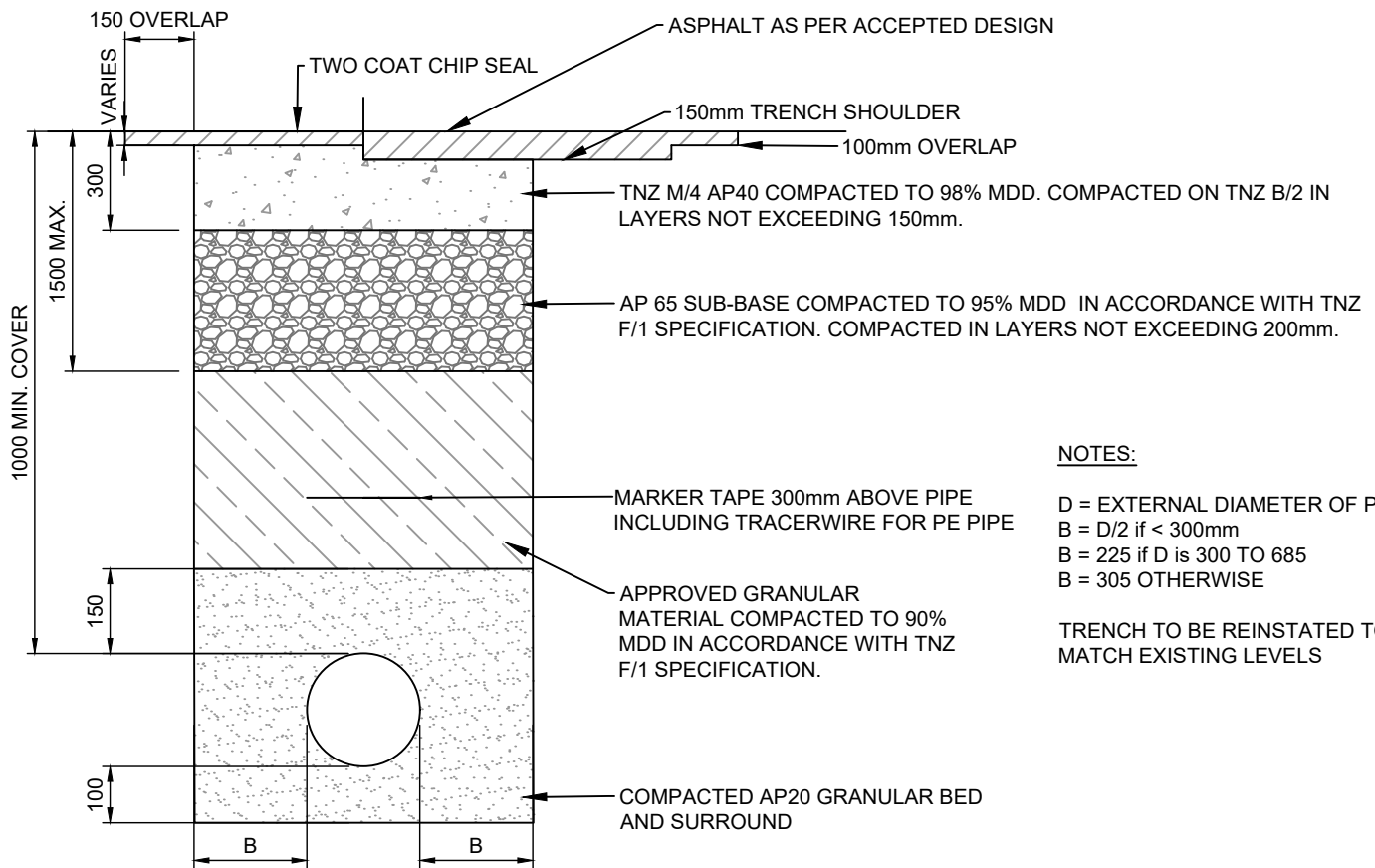

NOTES:

D = EXTERNAL DIAMETER OF PIPE
 B = D/2 if < 300mm
 B = 225 if D is 300 TO 685
 B = 305 OTHERWISE

TRENCH TO BE REINSTATED TO MATCH EXISTING LEVELS

CHIPSEAL CARRIAGEWAY CROSS SECTION

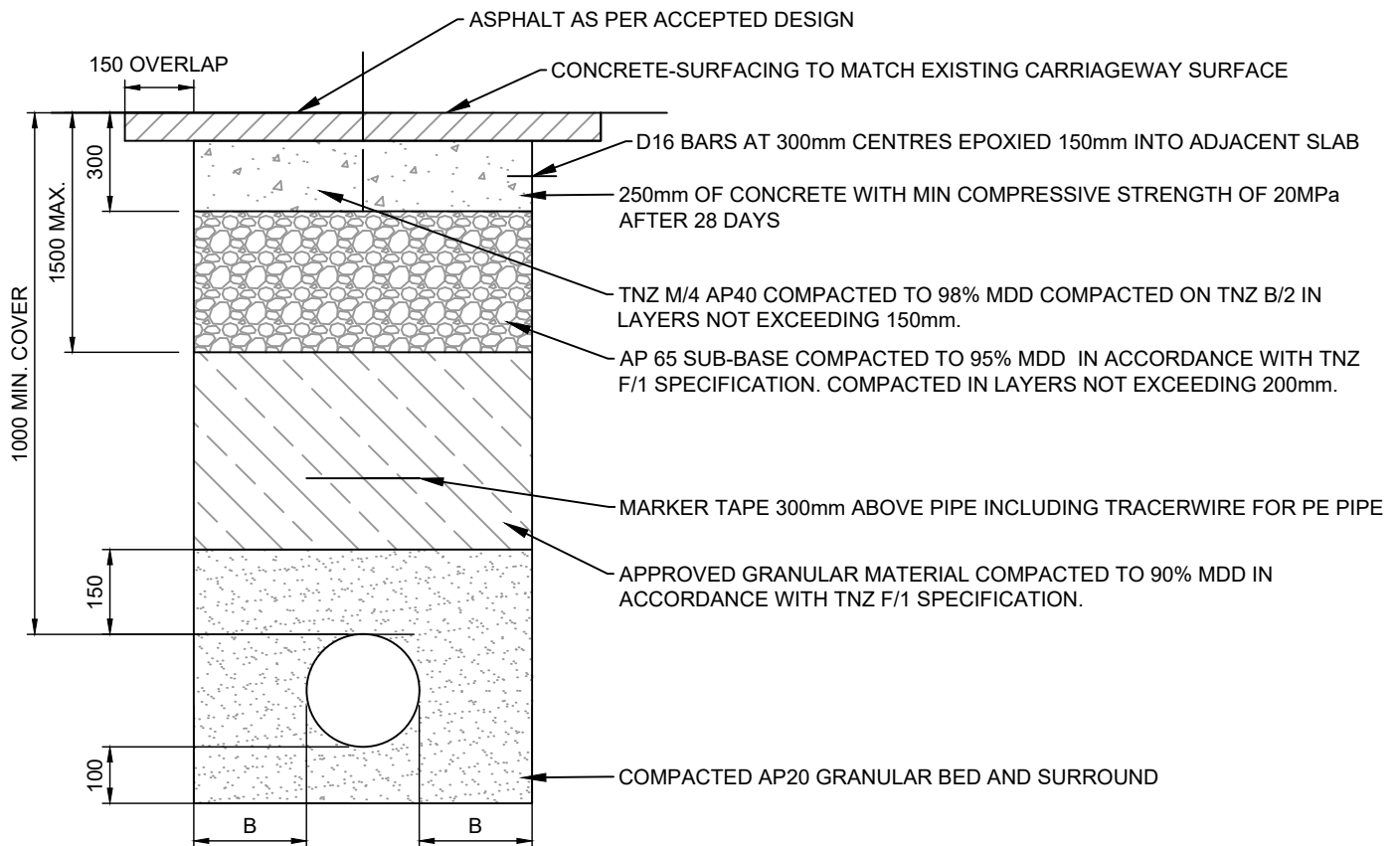

ASPHALT/CONCRETE CARRIAGEWAY CROSS SECTION

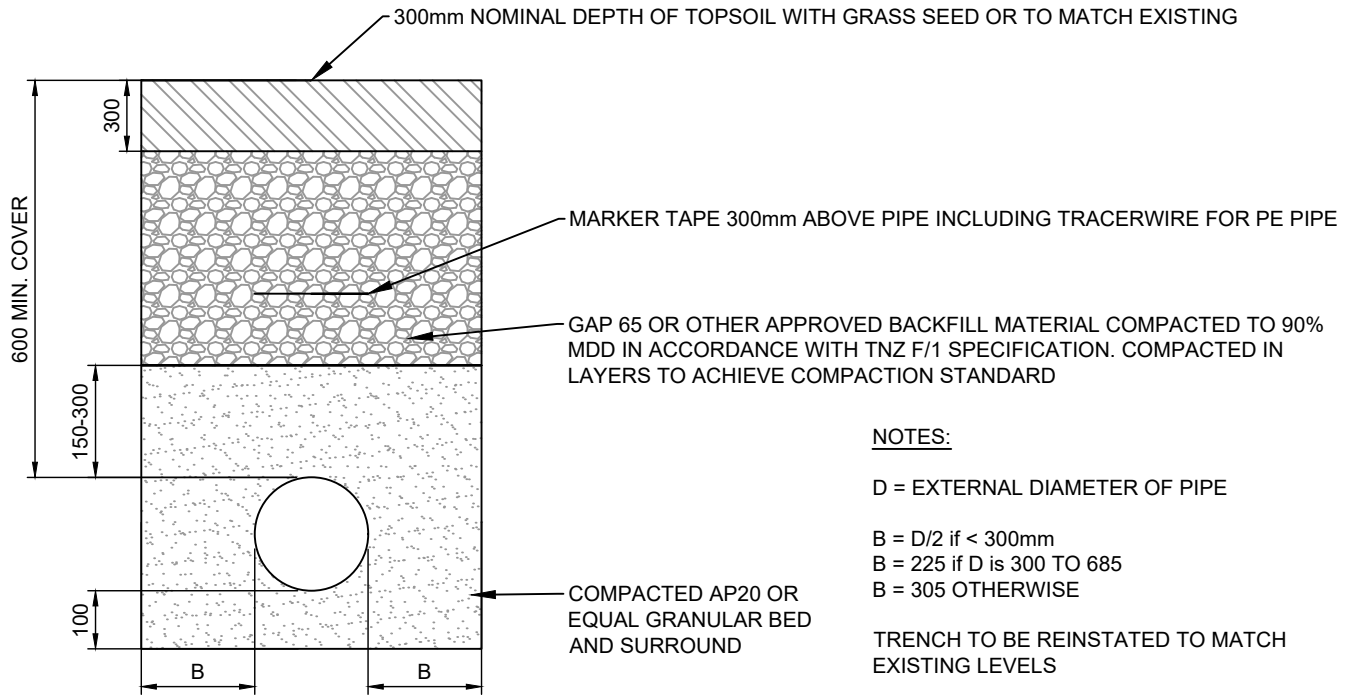

BERM/NON TRAFFICABLE CROSS SECTION

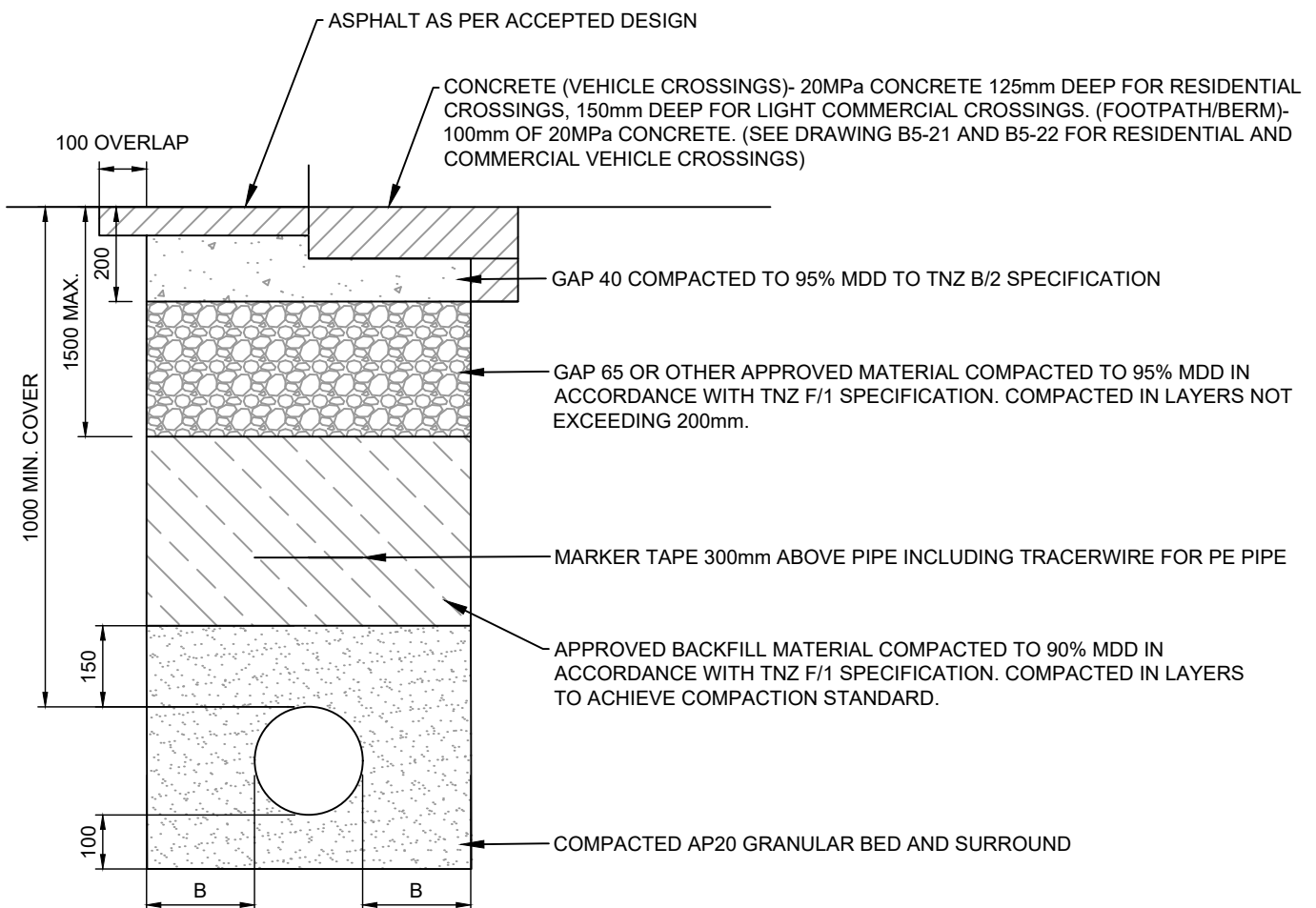

VEHICLE CROSSING CROSS SECTION

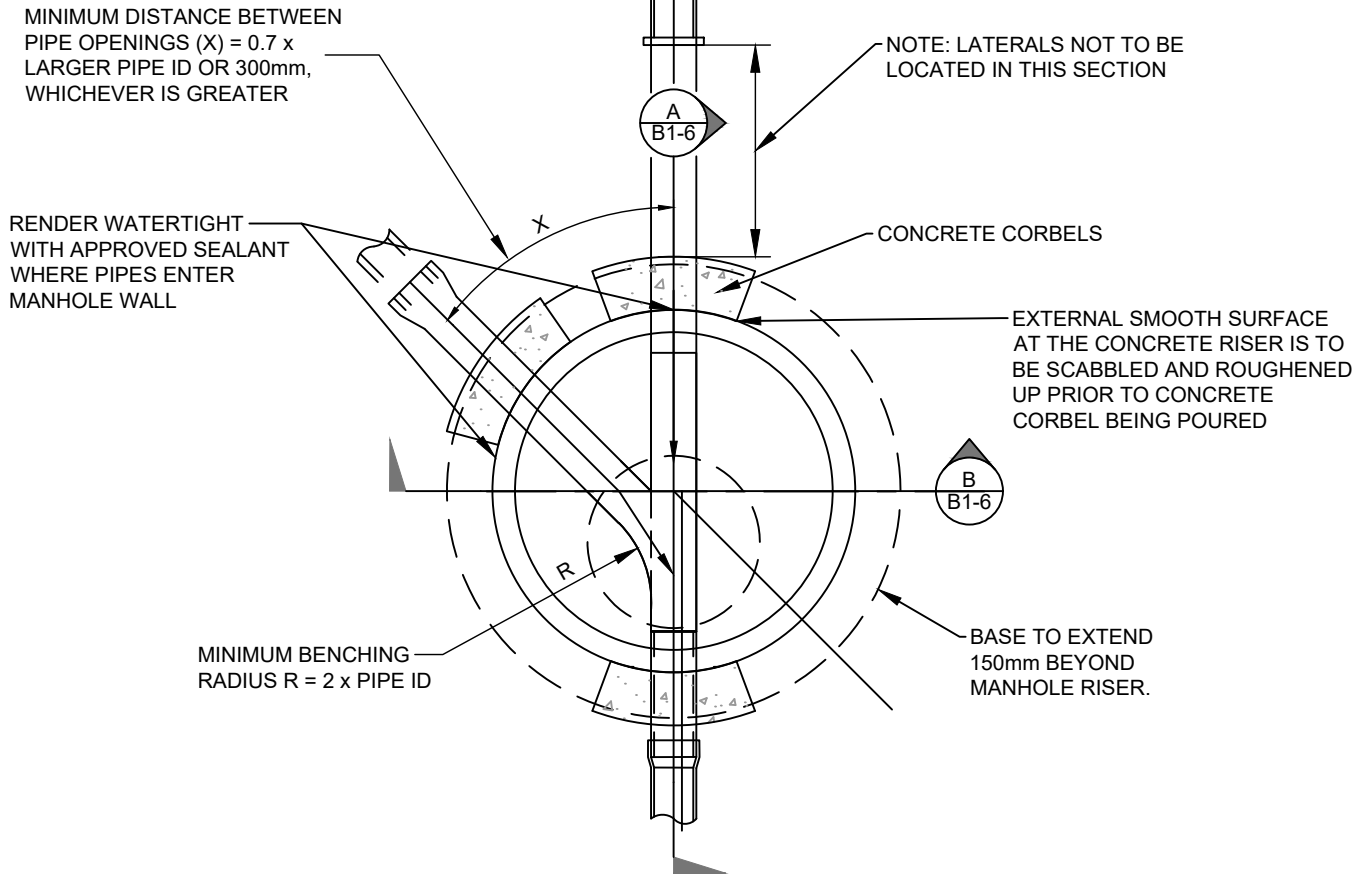

PLAN

NOTES

1. ALL IN SITU CONCRETE SHALL HAVE A MINIMUM COMPRESSIVE STRENGTH OF 20MPa @ 28 DAYS.
2. ALL PRECAST MANHOLE UNITS (SHOWN SHADED IN DRAWING B1-6) TO BE STANDARD MANUFACTURED UNITS. (IE. HUMES OR SIMILAR APPROVED)
3. ALL BRANCHES SHALL BE CONSTRUCTED SUCH THAT THEY CAN BE READILY ACCESSED BY CCTV CAMERA. THE CORBALS DETAIL (IE. CROSS SECTION) SHALL NOT BE COMPROMISED. IF REQUIRED, THE "STRAIGHT THROUGH" CHANNEL SHALL BE OFFSET FROM THE MANHOLE CENTRELIN AND THE BRANCH CHANNELLING LEFT STRAIGHT FOR A SUFFICIENT LENGTH TO ACHIEVE THE DESIRED RESULT.
4. ACCESS OPENING TO BE LOCATED OVER THE DOWNSTREAM SIDE OF THE MANHOLE.
5. IF A DEVIATION IS SOUGHT FROM THE REQUIREMENTS IN THE DETAIL ABOVE, JUSTIFIABLE CALCULATIONS MUST BE GIVEN AND BE TO COUNCIL'S SATISFACTION.
6. >75° DEFLECTION SHALL REQUIRE SPECIFIC DESIGN FOR MANHOLE RISERS FOR ANY DIAMETER OF PIPE >375mm.

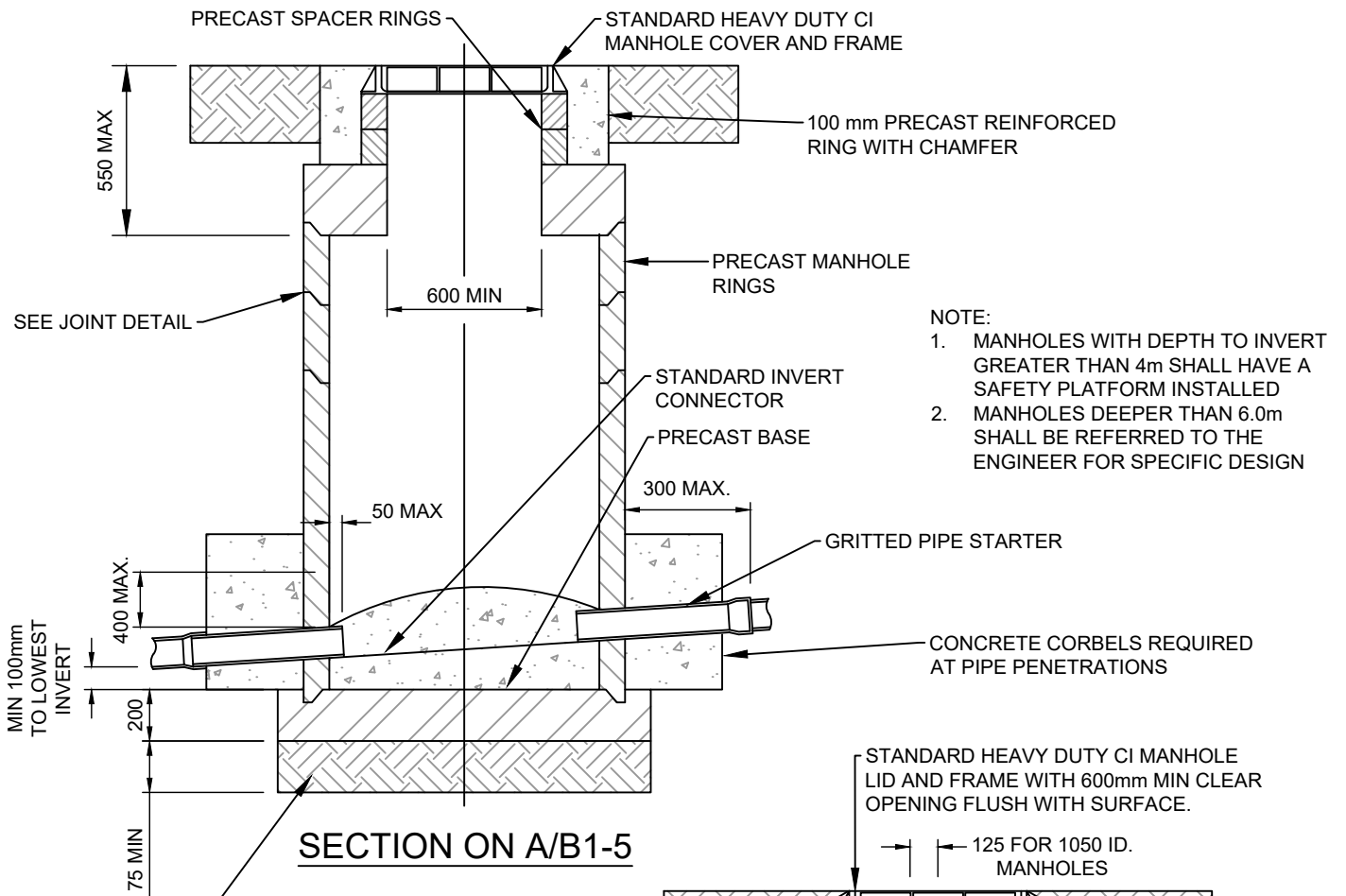

SECTION ON A/B1-5

COMPACTED FILL BEDDING TO DESIGNER SPECIFICATION ACCORDING TO GROUND CONDITIONS

PRECAST MANHOLE TOPSLAB 150mm MINIMUM THICK

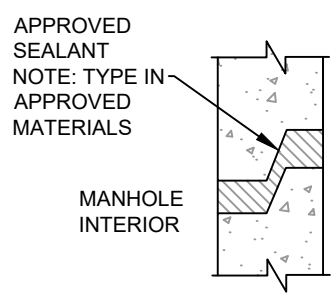

TYPICAL JOINT DETAIL

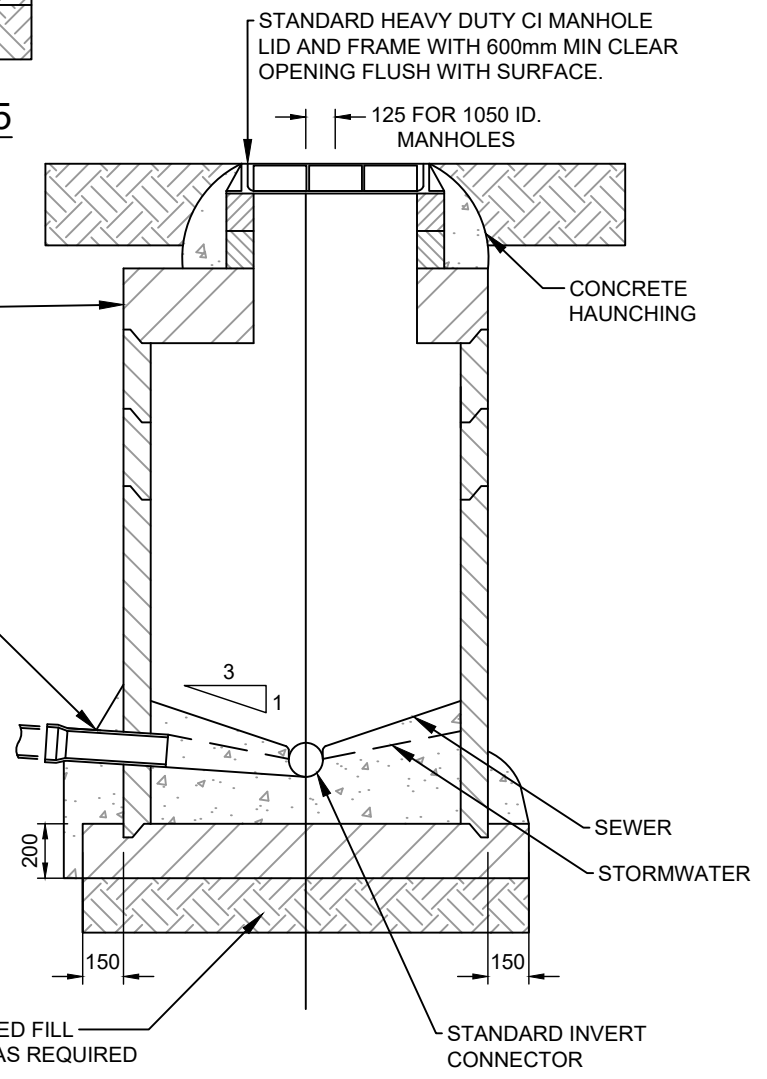

SECTION ON B/B1-5

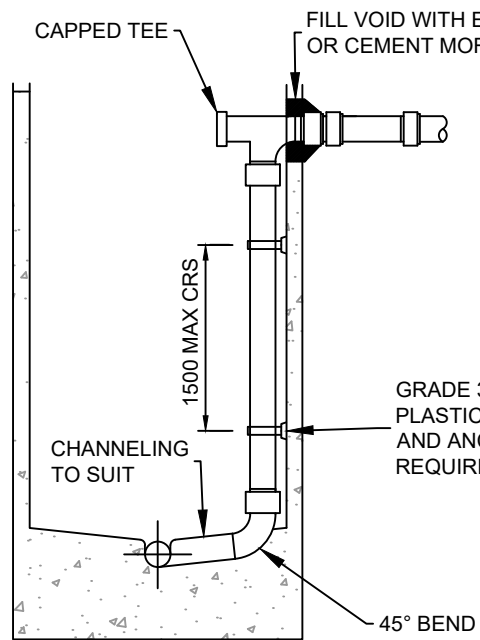

SECTION - INTERNAL DROP MANHOLE

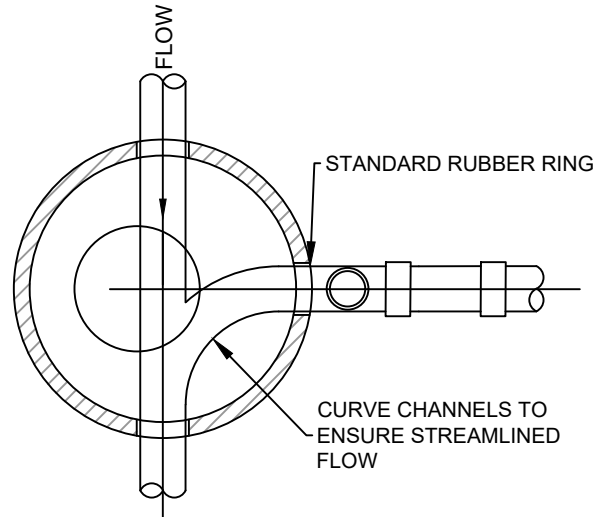

PLAN - EXTERNAL DROP MANHOLE

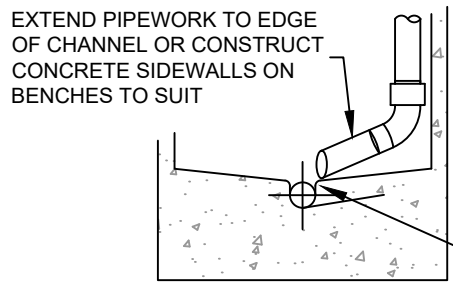

INTERNAL DROP POST CONSTRUCTION INSTALLATION DETAIL
(WHERE AUTHORISED BY TERRITORIAL AUTHORITY)

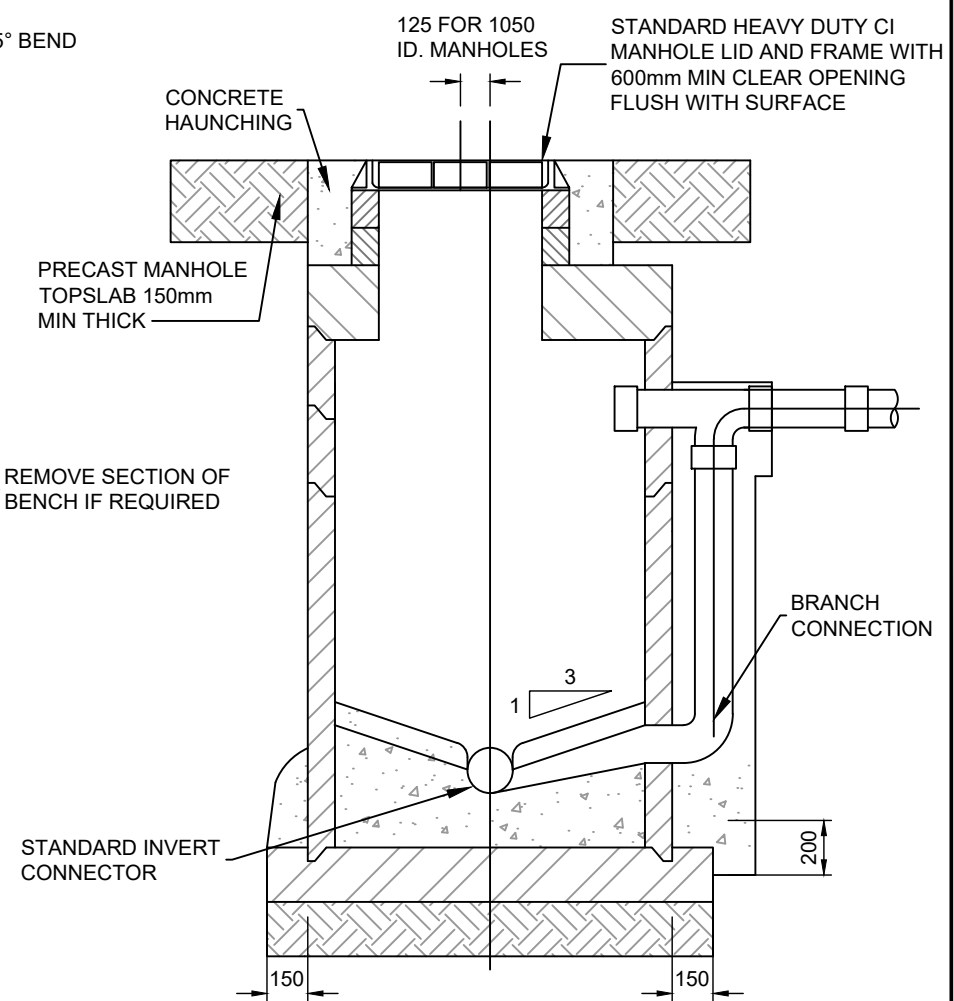

SECTION - EXTERNAL DROP MANHOLE

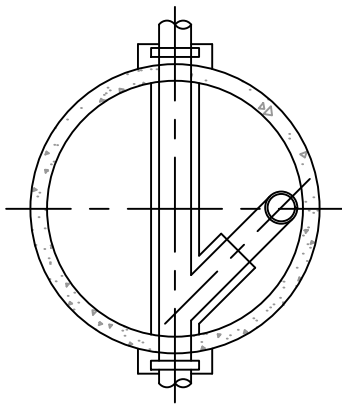

PLAN - TYPICAL INTERNAL DROP
SUITABLE FOR INSITU AND PRECAST MH (WHERE AUTHORISED BY TERRITORIAL AUTHORITY)

- NOTES:
1. ALL DIMENSIONS IN MILLIMETRES.
 2. MANHOLES WITH DEPTH TO INVERT GREATER THAN 4m SHALL HAVE A SAFETY PLATFORM INSTALLED.
 3. MANHOLES DEEPER THAN 6.0m SHALL BE REFERRED TO THE ENGINEER FOR SPECIFIC DESIGN.
 4. MINIMUM DN 1200 MH TO BE USED WITH INTERNAL DROP STRUCTURES.
 5. INTERNAL DROP NOT NORMALLY USED IN STORMWATER APPLICATIONS.
 6. ALL CAST IN-SITU BENCHING AND HAUNCHING TO BE 30MPa CONCRETE UNLESS OTHERWISE SPECIFIED BY TA.

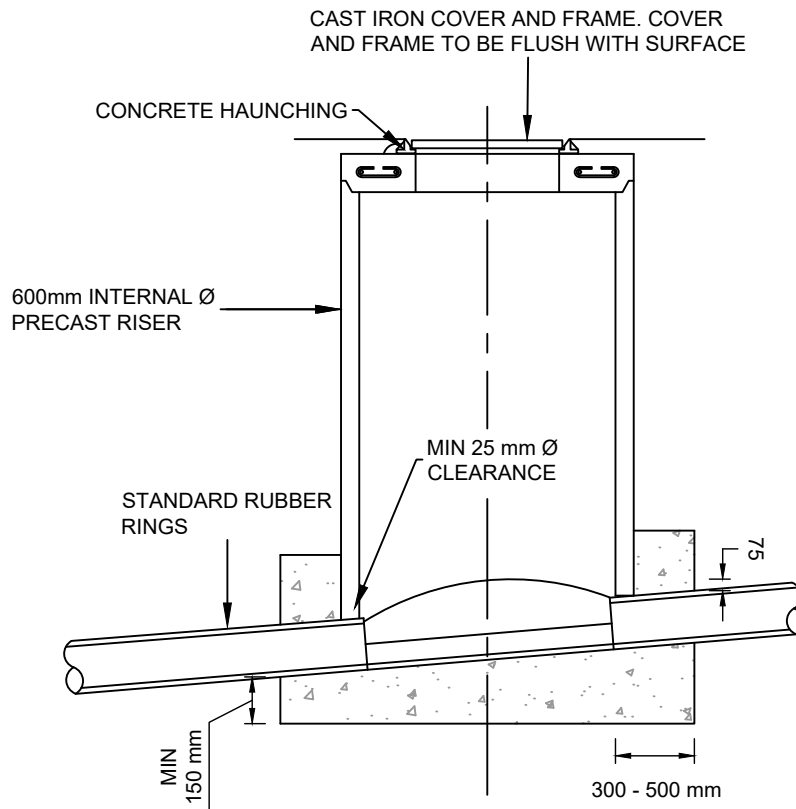

(DEPTH NOT TO EXCEED 1.2m)

MINI MANHOLE

NOTE:

1. ALL DIMENSIONS IN MILLIMETRES.
2. ALL CAST IN-SITU BENCHING AND HAUNCHING TO BE 30MPa CONCRETE UNLESS OTHERWISE SPECIFIED BY TA.

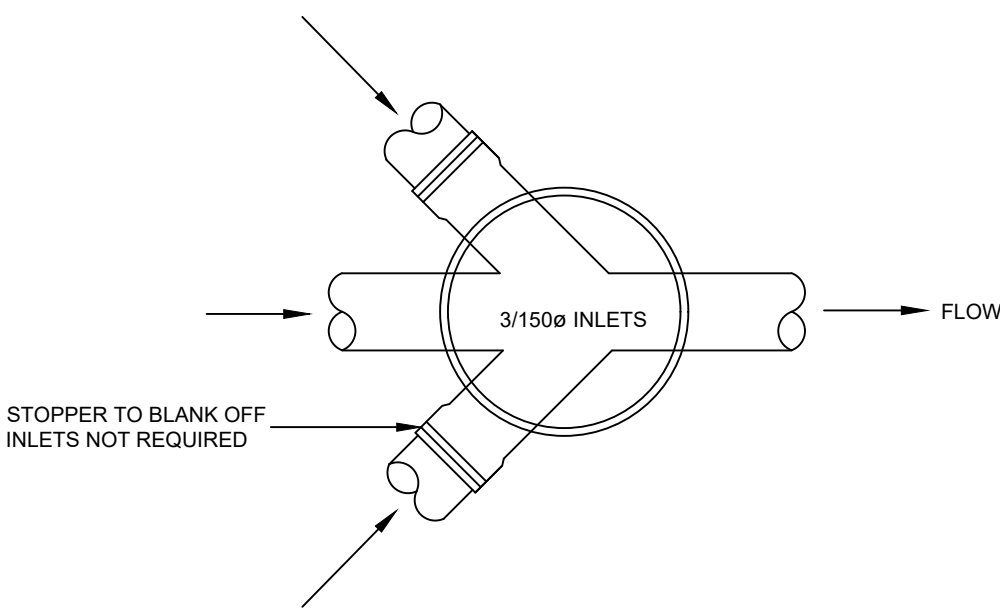
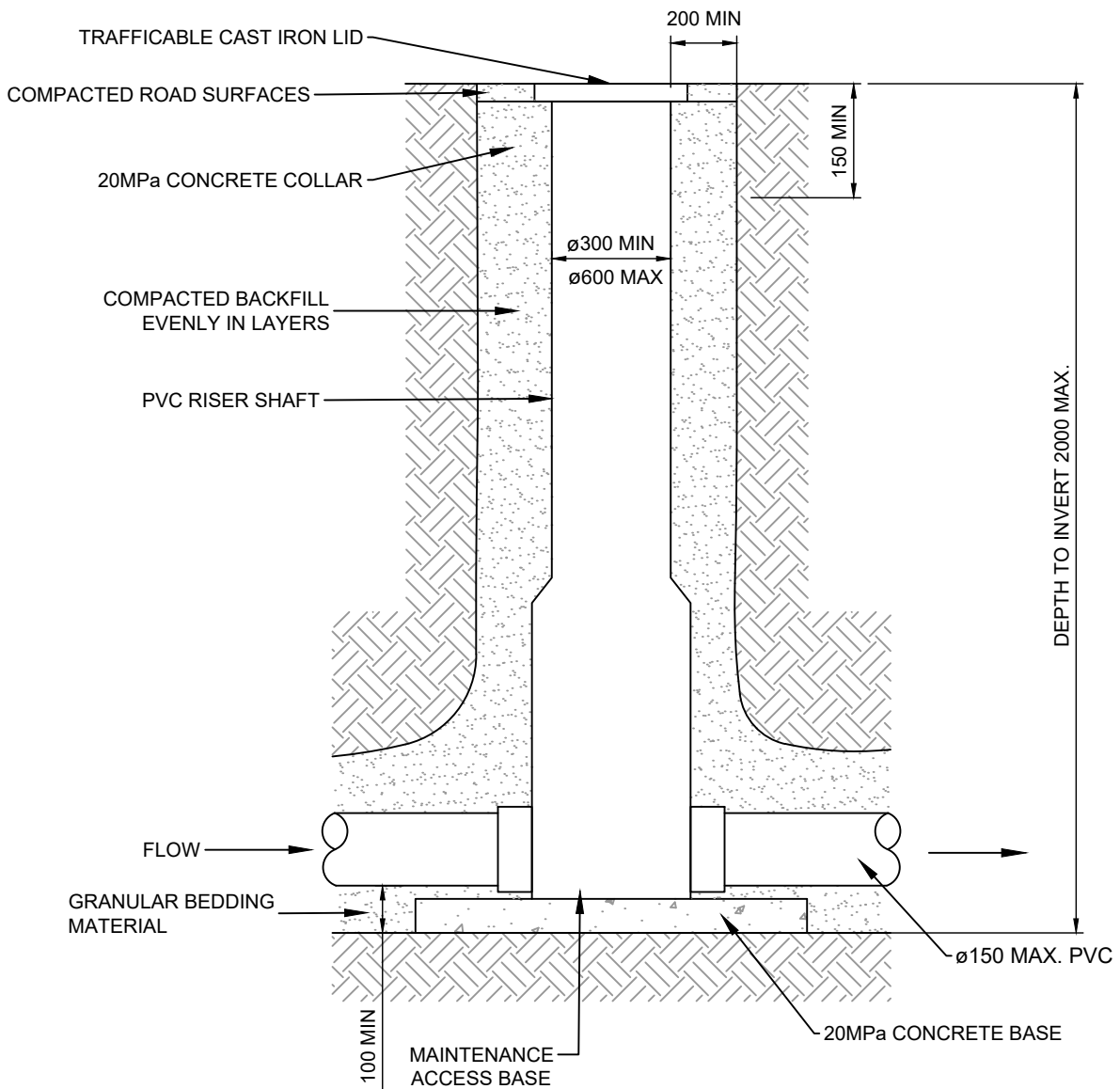

NOTE:
 ONLY TO BE USED FOR THE TERMINATING MANHOLES IN COMMON EASEMENTS OR RIGHT OF WAY ACCESS FOR RESIDENTIAL SITES WITH A MAXIMUM OF THREE 100mmØ HOUSE CONNECTIONS, OR WHERE DIRECTED BY THE ENGINEER.

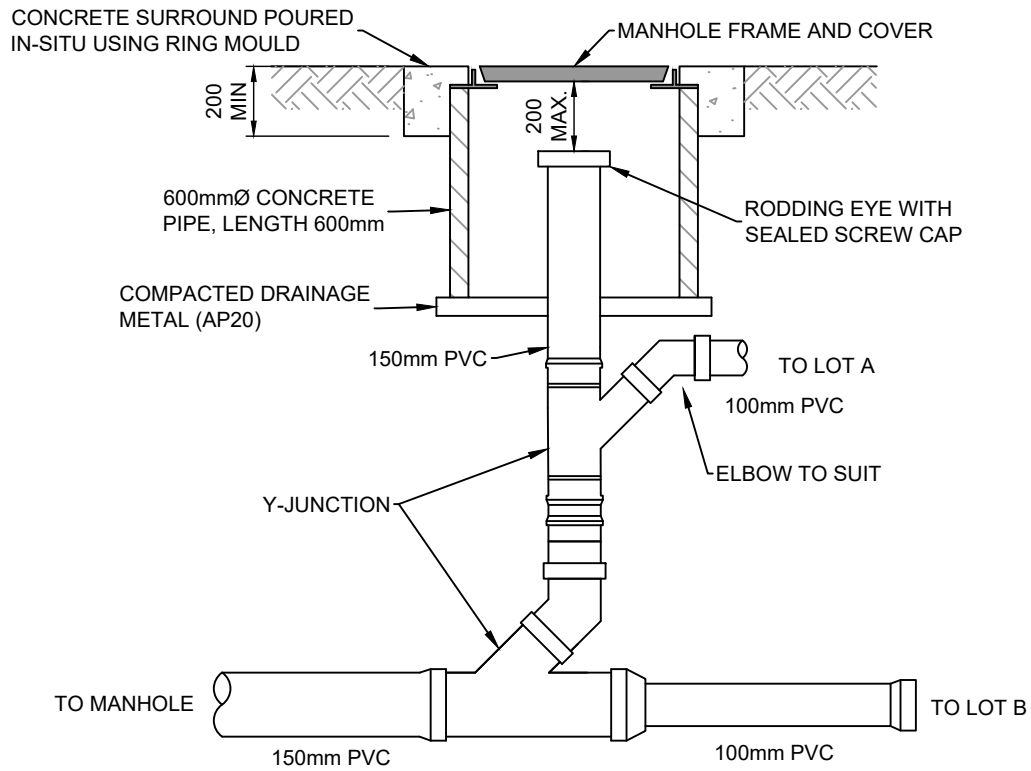

LATERAL OFF RODDING EYE STANDPIPE

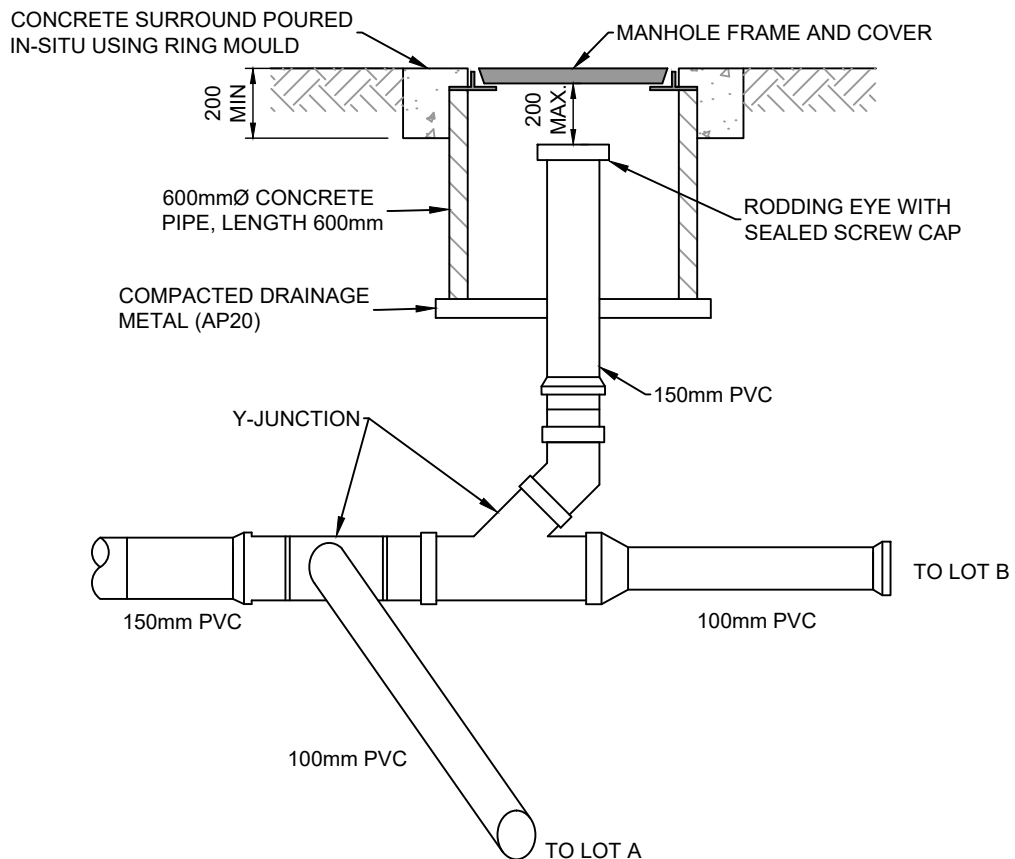

LATERAL OFF 150mm CONNECTION TO MANHOLE

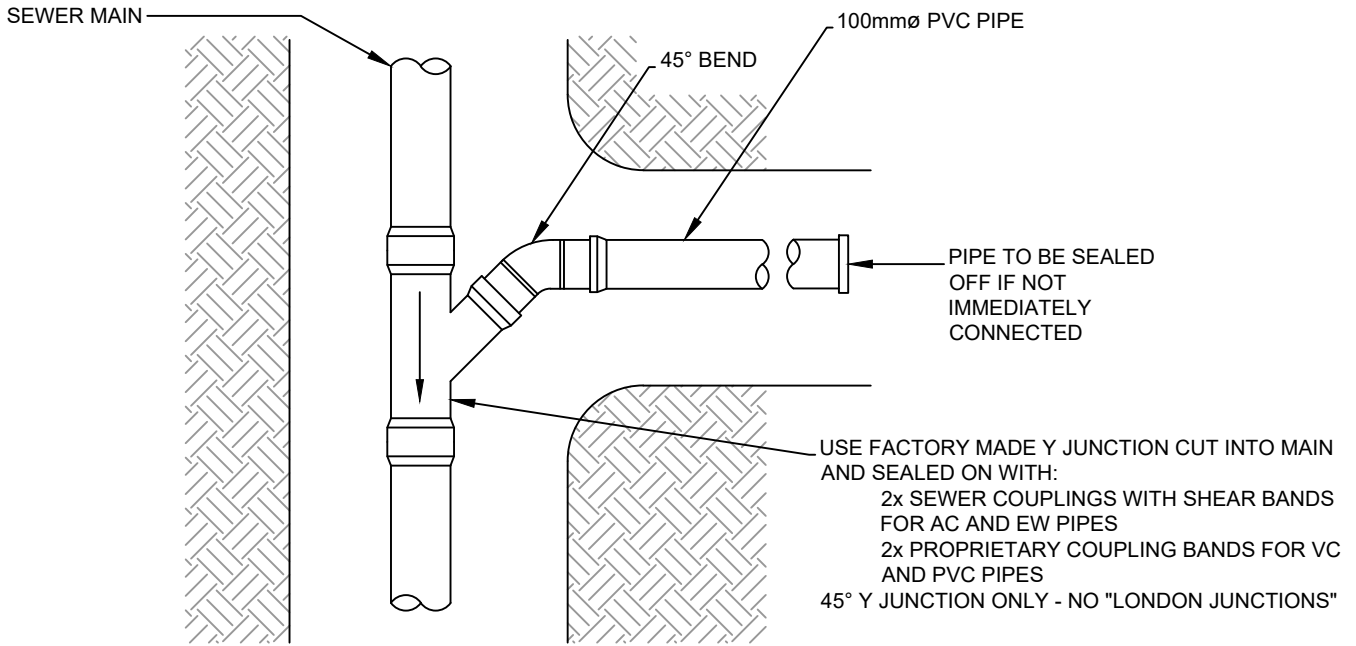

PLAN VIEW

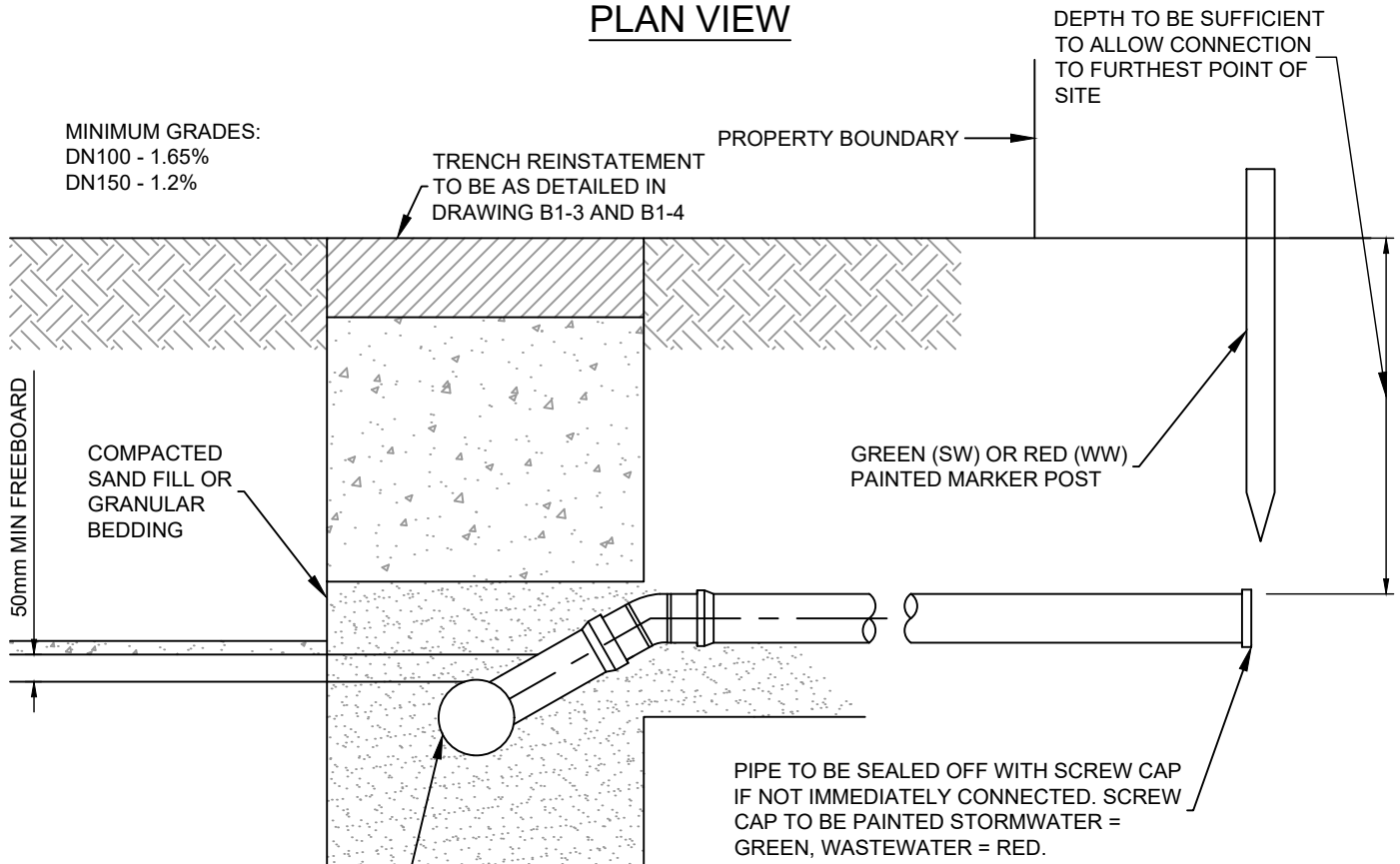

USE FACTORY MADE Y JUNCTION CUT INTO MAIN AND SEALED ON WITH:
 2x SEWER COUPLINGS WITH SHEAR BANDS FOR AC AND EW PIPES
 2x PROPRIETARY COUPLING BANDS FOR VC AND PVC PIPES
 45° Y JUNCTION ONLY - NO "LONDON JUNCTIONS"

SHALLOW CONNECTION

DEPTH TO INVERT LESS THAN 1.2m

NOTES:

- ALL CONNECTIONS SHALL HAVE NO ACCESS FITTINGS ON LINE, NO CHANGE OF DIRECTION, OR CHANGE OF GRADE WITHIN 3m OF MAIN CONNECTION.

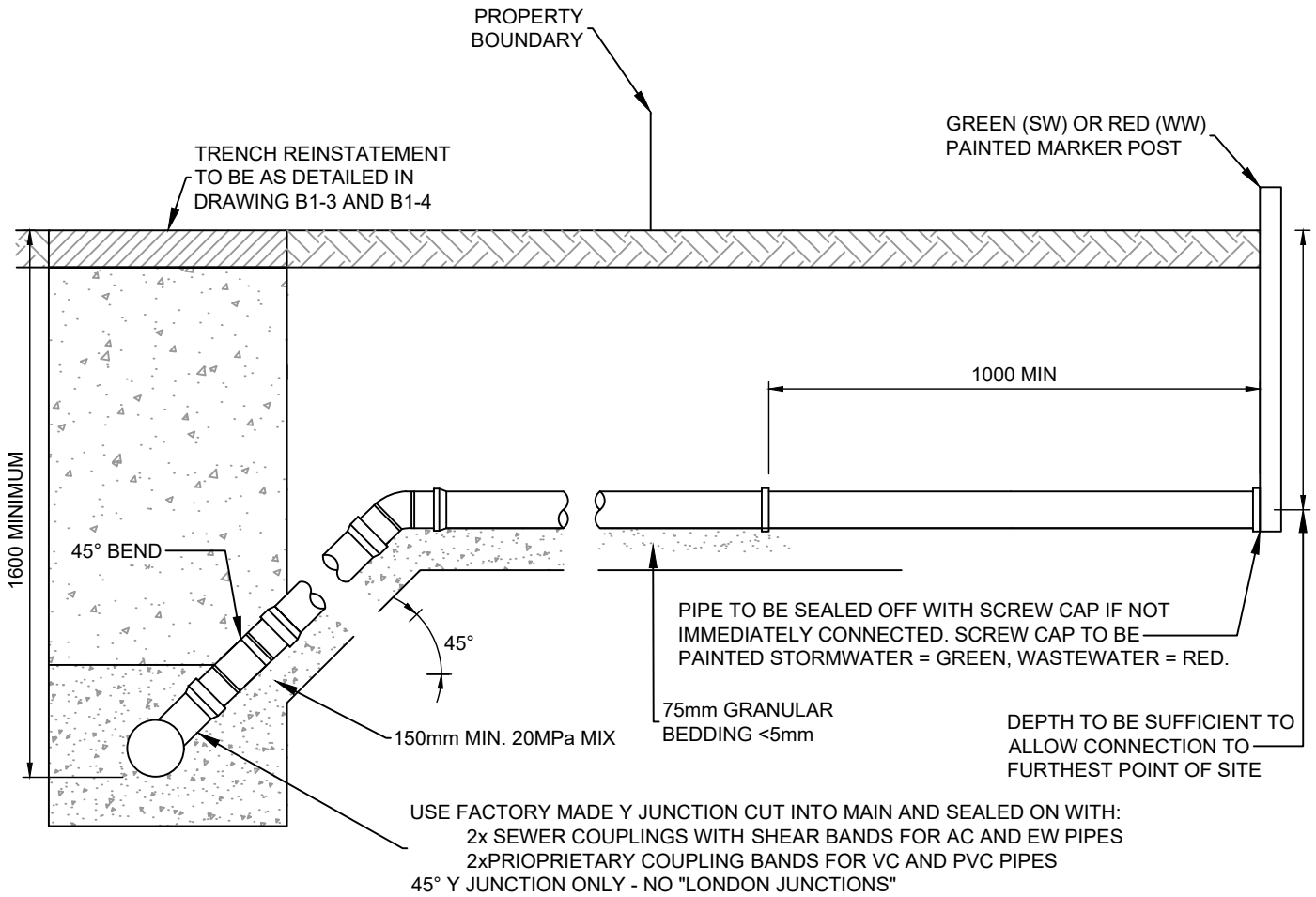

DEEP CONNECTION
 DEPTH TO INVERT MORE THAN 1.2m

QLDC LDSC 2020
 Standard Details
 Revision:
 Rev Date:



Drawing Title:
Domestic Drainage (Deep Connection) Detail

NOT TO SCALE
 Drawing No.
B1-12

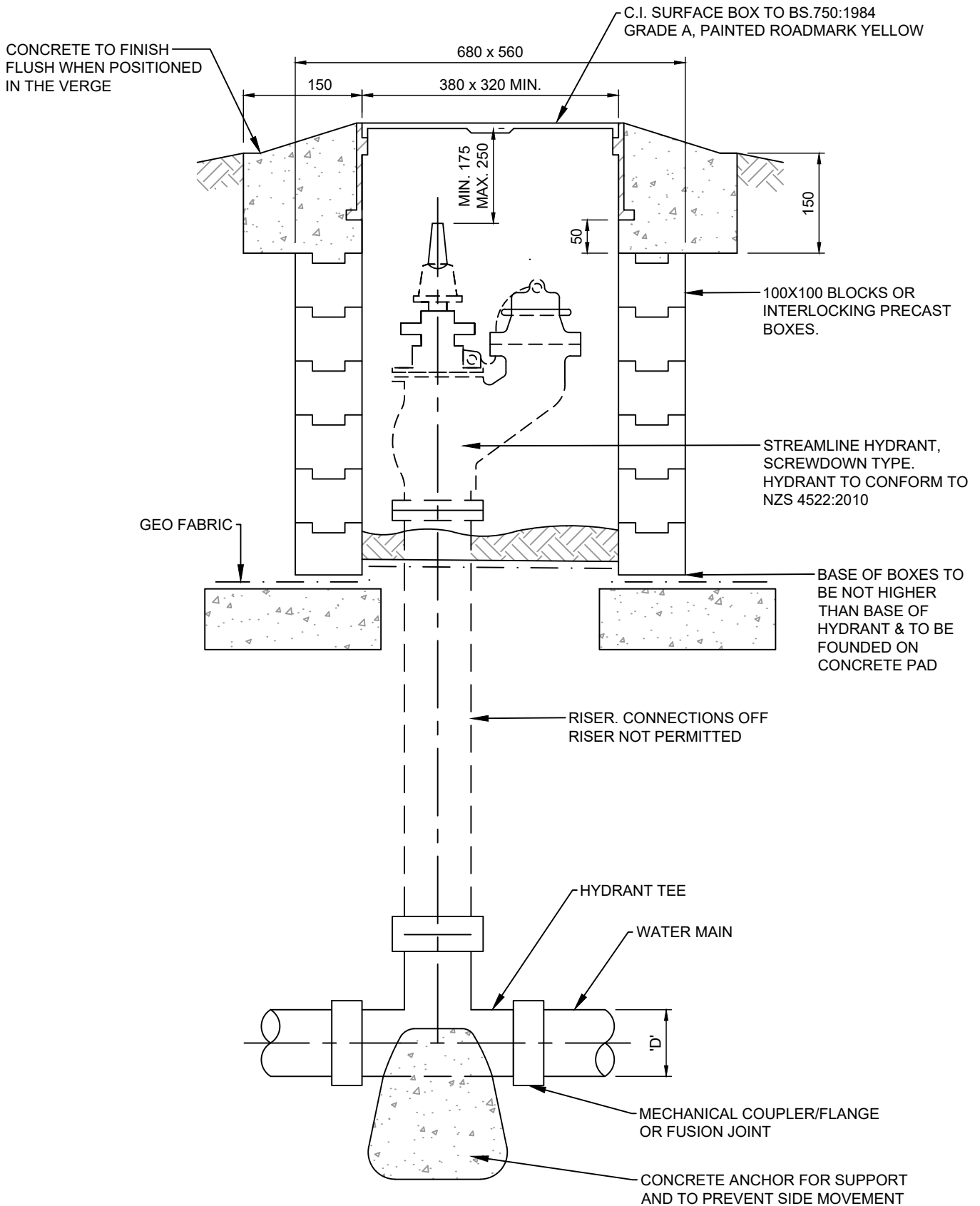

NOTES:

1. ALL DIMENSIONS IN MILLIMETRES.
2. WHERE MAINS ARE CONSTRUCTED IN PVC, USE STANDARD CAST IRON HYDRANT TEE AND STEP MECHANICAL COUPLER.
3. FROST PLUG TO BE INSTALLED.
4. ALL FIRE HYDRANTS SHALL BE INSTALLED ON SUPPLY PIPES THAT HAVE A MINIMUM COVER OF 1000mm TO ALLOW FOR SUITABLE CLEARANCES, IF REQUIRED LOCALISED LOWERING OF THE SUPPLY PIPES CAN BE ACHIEVED BY TAPERING DOWN FROM 5m EITHER SIDE OF THE FIRE HYDRANT.

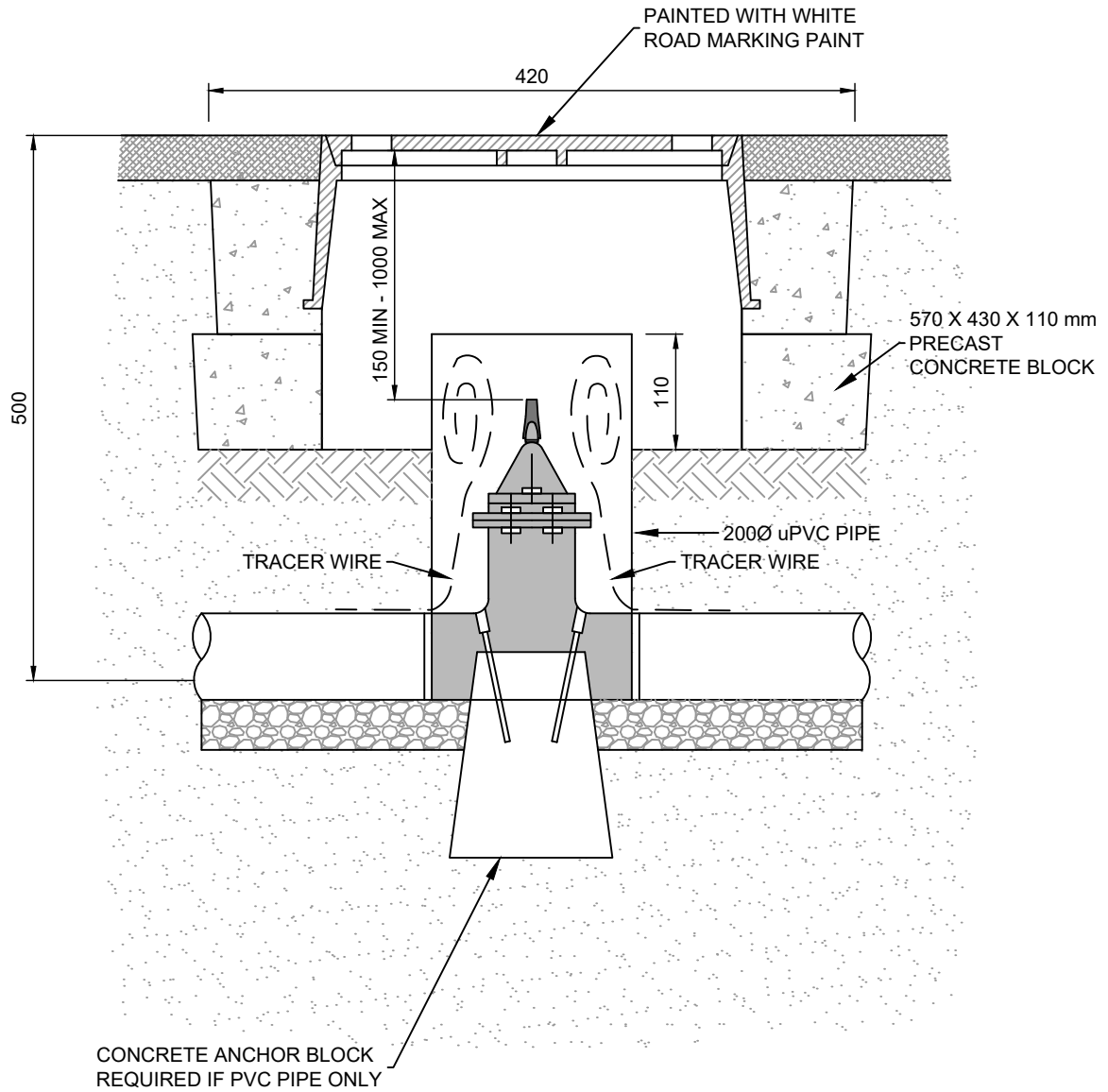

NOTES:

1. CONCRETE SURROUNDS 370x480x90H Ø200 HOLE FITS CAST IRON VALVE BOX 225x235
2. FIRE HYDRANT CONCRETE SURROUND 570x430x110H FITS 405x255 SV OR FH CAST IRON BOX

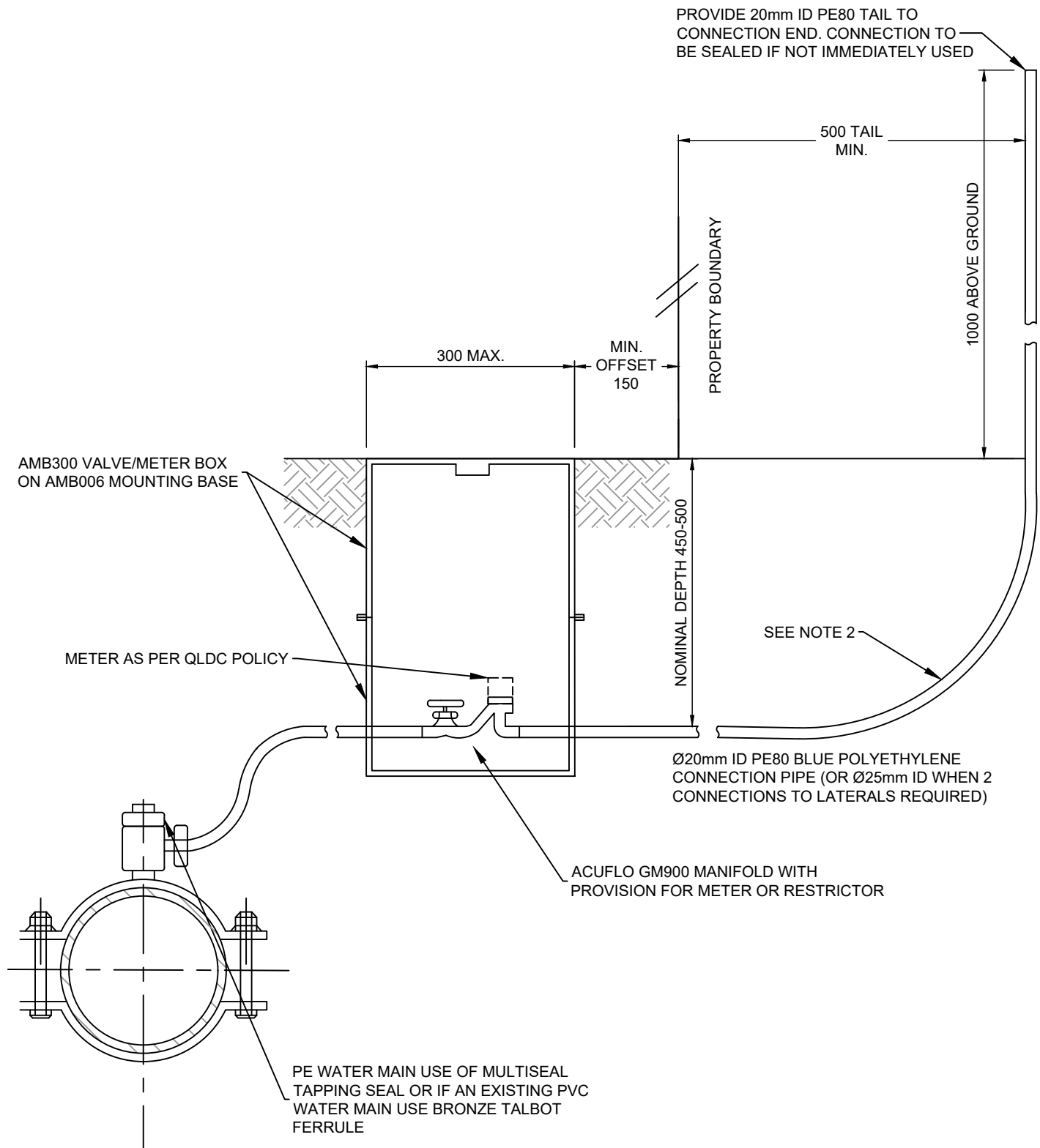

NOTES:

1. OPTION OF USING 50 mm BRASS TALBOT INSTEAD OF ELBOW OFF MAIN.
2. OPTION OF A CONTINUOUS PIPE LAID IN ACCORDANCE WITH MANUFACTURE MINIMUM BEND RADIUS, AND IF THIS CANNOT BE ACHIEVED THEN ELECTRO FUSION (EF) ELBOWS ARE TO BE USED.
3. WHEN THERE IS NO OPTION BUT TO INSTALL A TOBY BOX IN A TRAFFICABLE AREA THEN A TRAFFICABLE CAST BOX WITH CAST IRON LID IS REQUIRED.
4. 25mm ID CONNECTIONS REQUIRE 2 x ACUFLO BOXES OR 500mm JUMBO BOX WITH BASES.
5. AN ACUFLO GM900 MANIFOLD WITH BLANK CAP AND SCREW-IN DUAL CHECK VALVE SHALL BE INSTALLED ON EACH CONNECTION AND POSITIONED INSIDE AN AMB035 (LID-LESS BOX/BASE COMBINATION) WITH A AMB300 (300mm WITH LID) BOX POSITIONED ABOVE TO GIVE REQUIRED DEPTH (450mm) NEAR THE PROPERTY BOUNDARY AND ALSO BE CLEAR OF ANY VEHICULAR MOVEMENTS.

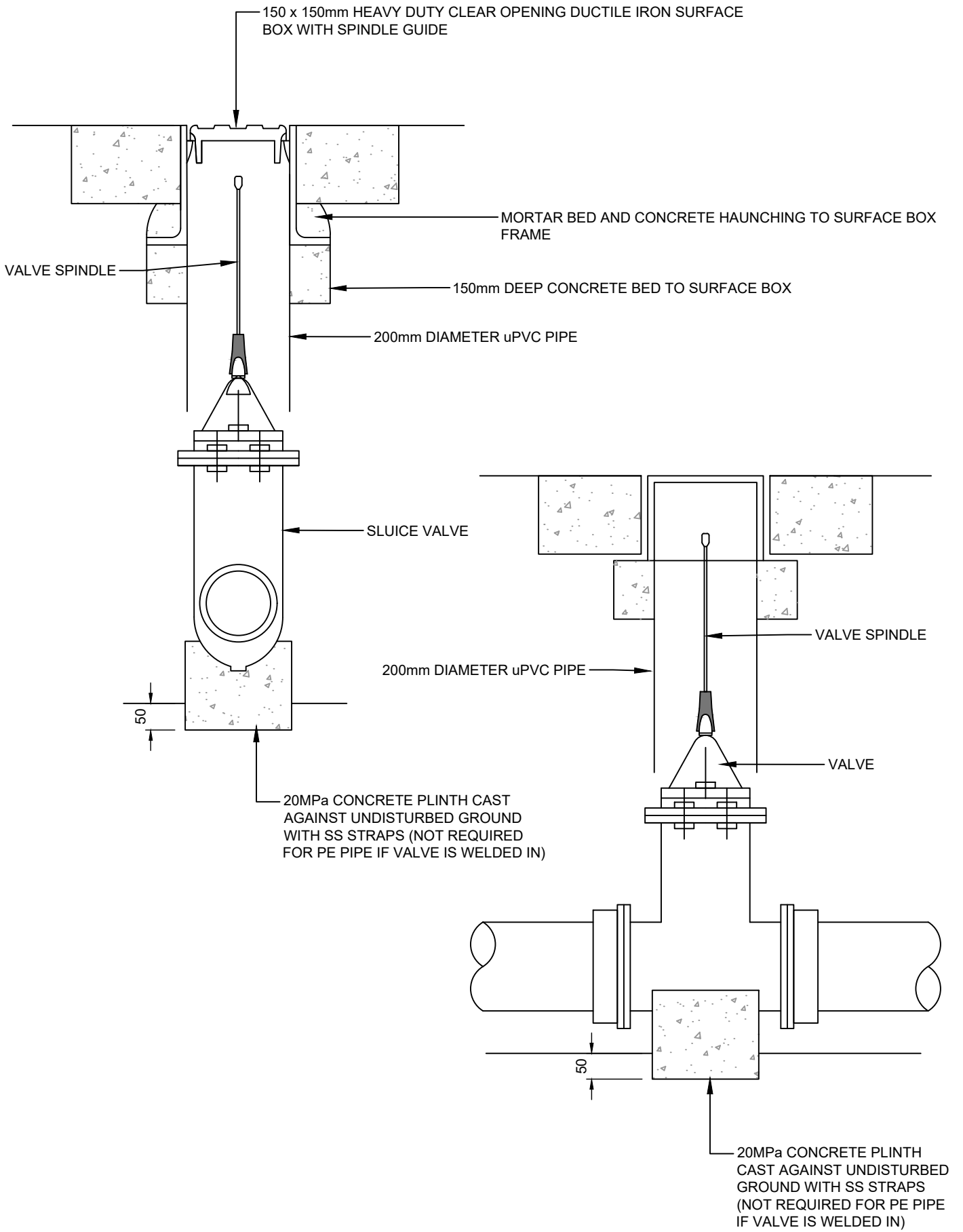

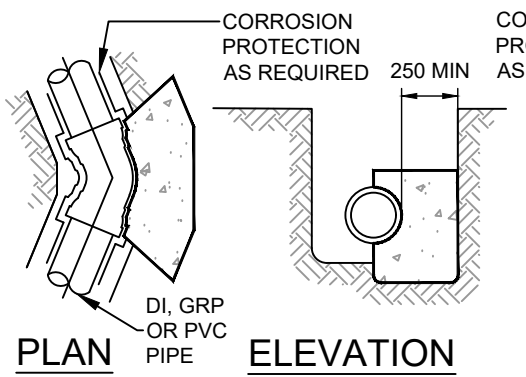

PLAN **ELEVATION**
THRUST BLOCK FOR BENDS
 (FOR HORIZONTAL THRUST)

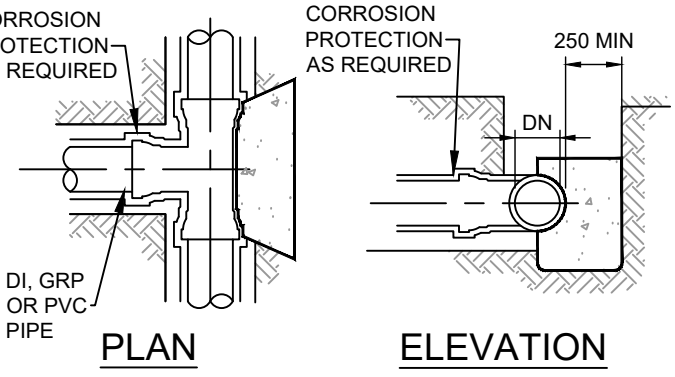

PLAN **ELEVATION**
THRUST BLOCK FOR TEES
 (FOR HORIZONTAL THRUST)

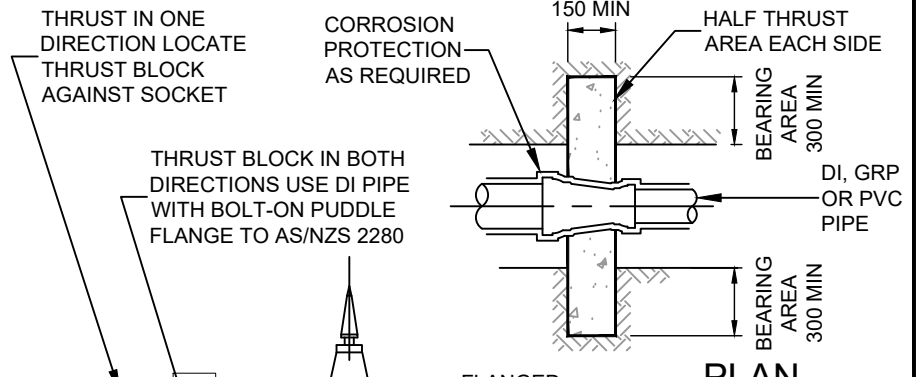

PLAN
TAPER THRUST BLOCK
 (FOR HORIZONTAL THRUST)

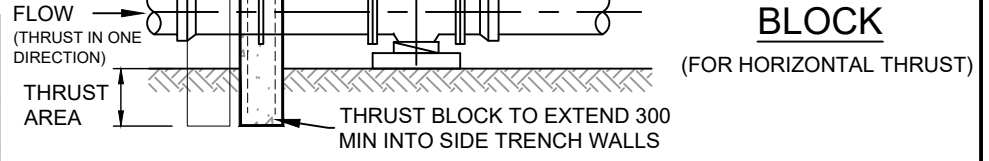

ELEVATION
CONCRETE THRUST BLOCK FOR FLANGED VALVES

- NOTES:**
- SOIL CLASSIFICATIONS USED IN THIS TABLE ARE EXPLAINED IN APPENDIX G OF WSA 03.
 - CAST THE THRUST AREA OF ALL THRUST BLOCKS AGAINST A CLEAN FACE OF UNDISTURBED NATURAL SOIL. THRUST BLOCKS NOT TO INTERFERE WITH OTHER SERVICES.
 - DO NOT USE STANDARD THRUST BLOCKS IN:
 - VERY SOFT, SOFT OR FIRM CLAY;
 - LOOSE CLEAN SAND;
 - UNCOMPACTED FILL OR REFUSE;
 - A GEOTECHNICAL ASSESSMENT AND INDIVIDUAL DESIGN IS REQUIRED FOR THESE SOILS.
 - THE NOMINAL THRUST AREA 'N' TO BE ACHIEVED BY POURING CONCRETE THE FULL LENGTH OF THE FITTING AND EXTENDING FROM THE FLOOR OF THE TRENCH TO ABOVE THE FITTING (SEE NOTE 5).
 - FOR SYSTEM TEST PRESSURES OTHER THAN 1000 kPa REDUCE OR INCREASE THE MINIMUM THRUST AREA BY THE RATIO OF THE APPLICABLE PRESSURES EXCEPT WHERE:
 - THRUST AREA IS 0.18m^2, AND
 - 'N' APPEARS IN THE TABLE AND THE APPLICABLE PRESSURE IS ABOVE 1000 kPa CALCULATE THE AREA.
 - FINISH THRUST BLOCKS APPROXIMATELY 100 mm ABOVE THE TOP OF THE FITTING OR BEARING PAD AND EXTEND TO THE FLOOR OF THE TRENCH OR DEEPER IF NECESSARY TO ACHIEVE THE REQUIRED THRUST AREA. MAXIMUM ENCASEMENT TO BE 180°.
 - THE MINIMUM THRUST AREA FOR TAPER THRUST BLOCKS TO BE EQUAL TO THE DIFFERENCE BETWEEN THE THRUST AREAS FOR DEAD-ENDS OF EQUIVALENT DIAMETER TO THOSE EACH SIDE OF TAPER.
 - FOR DOWNWARD VERTICAL THRUST, THE ALLOWABLE BEARING PRESSURES FOR VARIOUS SOILS MAY BE TAKEN AS TWICE THAT FOR HORIZONTAL THRUST SHOWN.
 - WHEN POURING CONCRETE AGAINST FITTINGS PLACE A MEMBRANE OF POLYETHYLENE, PVC OR FELT BETWEEN THE FITTING AND CONCRETE TO PREVENT DAMAGE TO THE FITTING. JOINTS TO BE CLEAR OF CONCRETE.
 - CONCRETE TO BE KEPT CLEAR OF BOLTS & FLANGES OR GIBALT JOINTS TO ALLOW FITTINGS TO BE REMOVED WITHOUT INTERFERING WITH ANCHOR BLOCK.
 - THE USE OF THRUST BLOCKS IS GENERALLY NOT REQUIRED FOR PE PIPE. THRUST BLOCKS MAY BE REQUIRED IN CASES WHERE SPECIAL GASKETED MECHANICAL FITTINGS ARE USED.

SOIL CLASSIFICATION AND ALLOWABLE HORIZONTAL BEARING PRESSURE OF GROUND. (SEE NOTE 1)

FOR HORIZONTAL THRUST ON TRENCH WALLS WHERE THE COVER OVER PIPES IS 450 OR GREATER

NOMINAL DIAMETER OF FITTING (DN)	MINIMUM THRUST AREA FOR BLOCKS IN SQUARE METRES (m ²) DESIGN PRESSURE 1000 kPa (NOM. 100m HEAD)														
	90° & 60° HORIZONTAL BENDS			45° & 30° HORIZONTAL BENDS			22.5° HORIZONTAL BENDS			11.25° HORIZONTAL BENDS			TEES AND DEAD ENDS		
	STIFF CLAY MEDIUM-DENSE CLEAN SAND	VERY STIFF CLAY DENSE SAND/GRAVEL DECOMPOSED ROCK	HARD CLAY SOUND ROCK	STIFF CLAY MEDIUM-DENSE CLEAN SAND	VERY STIFF CLAY DENSE SAND/GRAVEL DECOMPOSED ROCK	HARD CLAY SOUND ROCK	STIFF CLAY MEDIUM-DENSE CLEAN SAND	VERY STIFF CLAY DENSE SAND/GRAVEL DECOMPOSED ROCK	HARD CLAY SOUND ROCK	STIFF CLAY MEDIUM-DENSE CLEAN SAND	VERY STIFF CLAY DENSE SAND/GRAVEL DECOMPOSED ROCK	HARD CLAY SOUND ROCK	STIFF CLAY MEDIUM-DENSE CLEAN SAND	VERY STIFF CLAY DENSE SAND/GRAVEL DECOMPOSED ROCK	HARD CLAY SOUND ROCK
PBH kPa	50	100	200	50	100	200	50	100	200	50	100	200	50	100	200
100	0.32	N	N	N	N	N	N	N	N	N	N	N	.023	N	N
150	0.68	0.34	N	0.37	N	N	0.19	N	N	N	N	N	0.48	0.24	N
200	1.07	0.54	0.27	0.58	0.29	N	0.30	N	N	N	N	N	0.76	0.38	0.19
225	1.46	0.73	0.37	0.79	0.40	0.20	0.40	0.20	N	0.20	N	N	1.03	0.52	0.26
250	1.64	0.82	0.41	0.88	0.44	0.22	0.45	0.23	N	0.23	N	N	1.16	0.58	0.29
300	2.59	1.30	0.65	1.40	0.70	0.35	0.72	0.36	N	0.36	N	N	1.83	0.92	0.46
375	3.95	1.98	0.99	2.14	1.07	0.53	1.09	0.55	0.27	0.55	0.27	N	2.79	1.40	0.70
450	5.60	2.80	1.40	3.03	1.51	0.76	1.54	0.77	0.39	0.78	0.39	0.19	3.96	1.98	0.99
500	6.16	3.08	1.54	3.34	1.67	0.83	1.70	0.85	0.43	0.85	0.43	0.21	4.36	2.18	1.09
600	9.69	4.84	2.42	5.24	2.62	1.31	2.67	1.34	0.67	1.34	0.67	0.34	6.85	3.43	1.71
750	14.40	7.20	3.60	7.79	3.90	1.95	3.97	1.99	0.99	2.00	1.00	0.50	10.18	5.09	2.54

N DENOTES NOMINAL THRUST AREA - (SEE NOTES 4 & 5) PBH - ALLOWABLE HORIZONTAL BEARING PRESSURE

QLDC LDSC 2020
 Standard Details
 Revision:
 Rev Date:



Drawing Title:

Typical Thrust Block Details

NOT TO SCALE

Drawing No.
B2-5

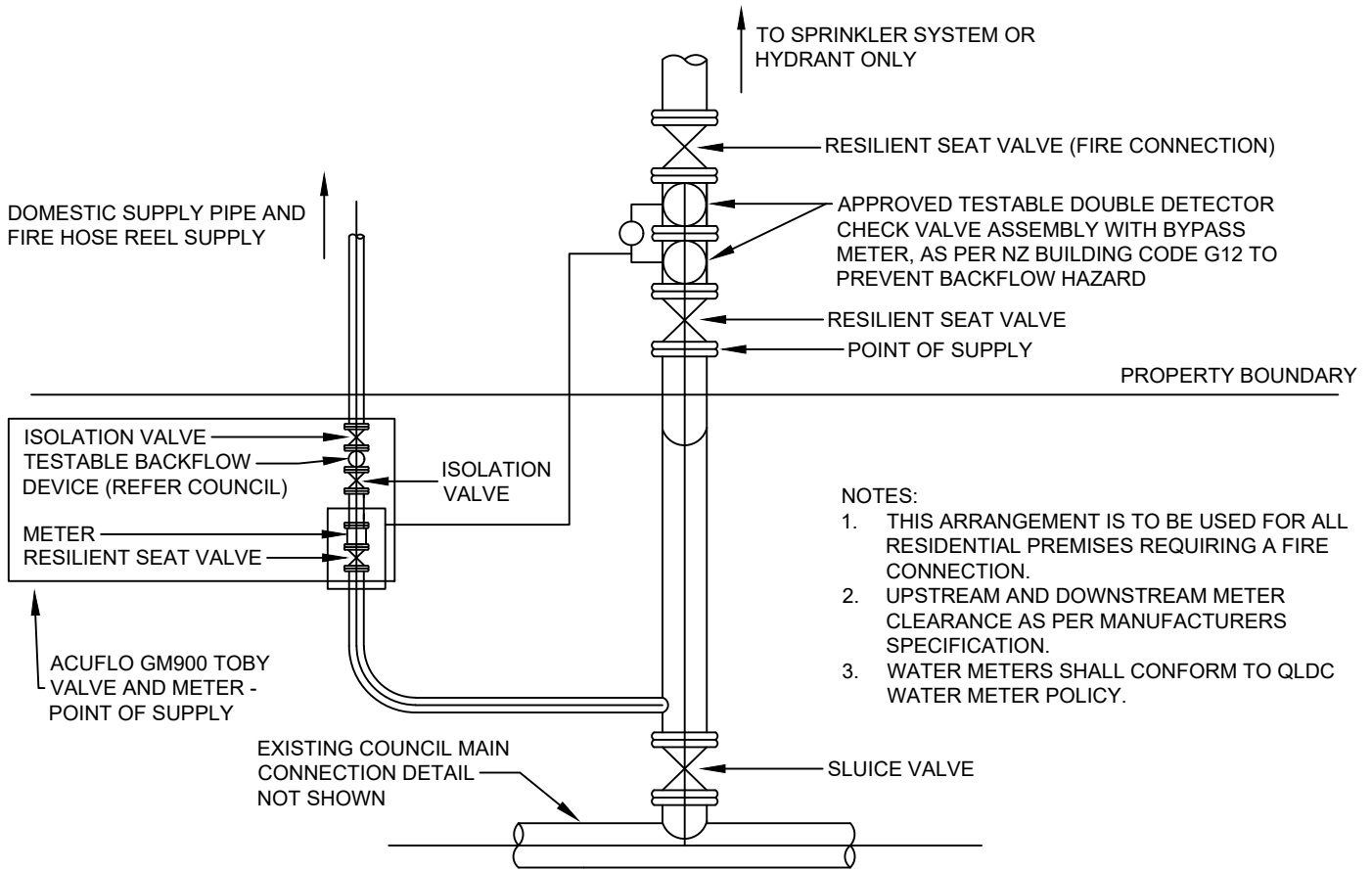

- NOTES:
1. THIS ARRANGEMENT IS TO BE USED FOR ALL RESIDENTIAL PREMISES REQUIRING A FIRE CONNECTION.
 2. UPSTREAM AND DOWNSTREAM METER CLEARANCE AS PER MANUFACTURERS SPECIFICATION.
 3. WATER METERS SHALL CONFORM TO QLDC WATER METER POLICY.

PLAN

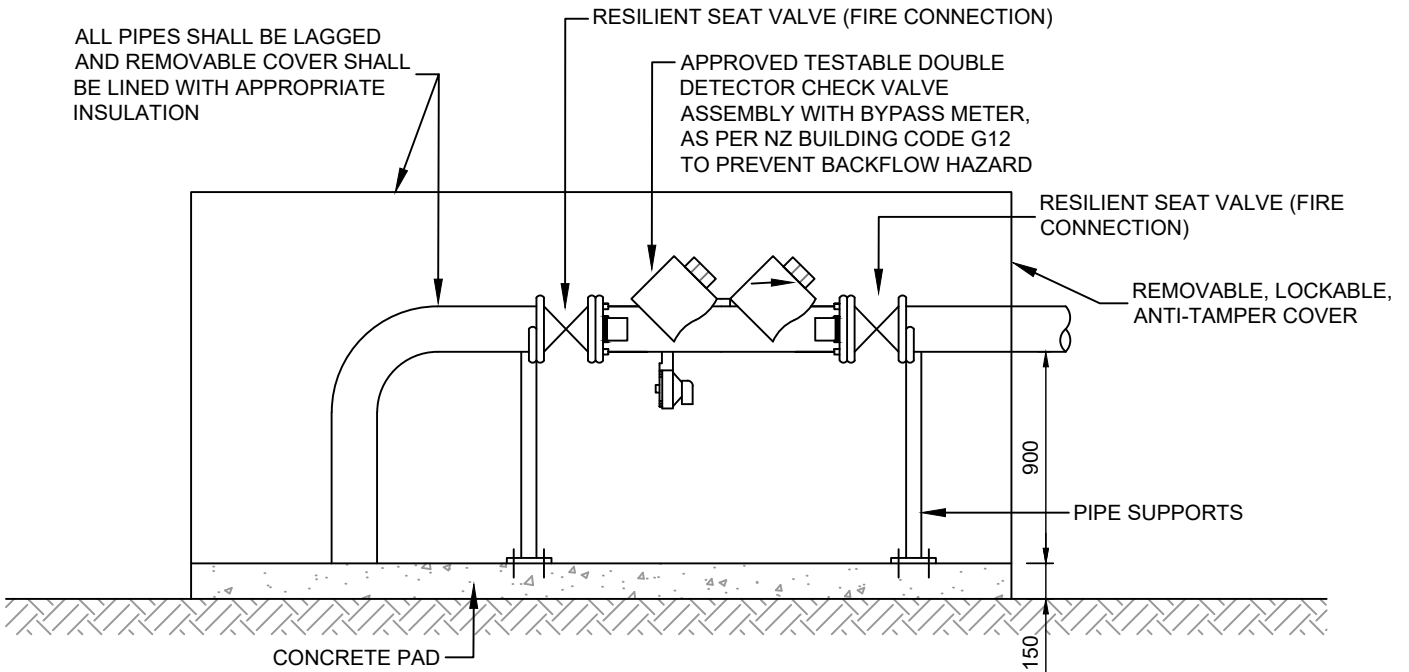

SIDE ELEVATION

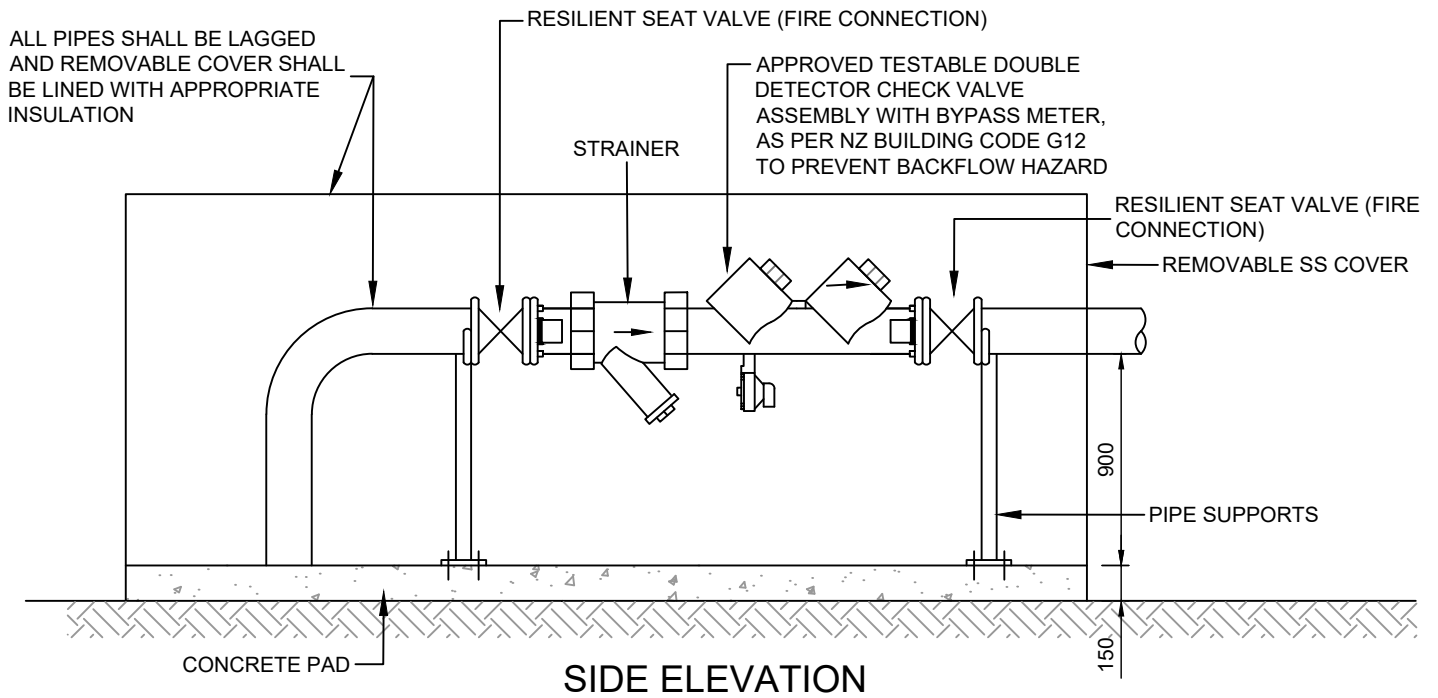
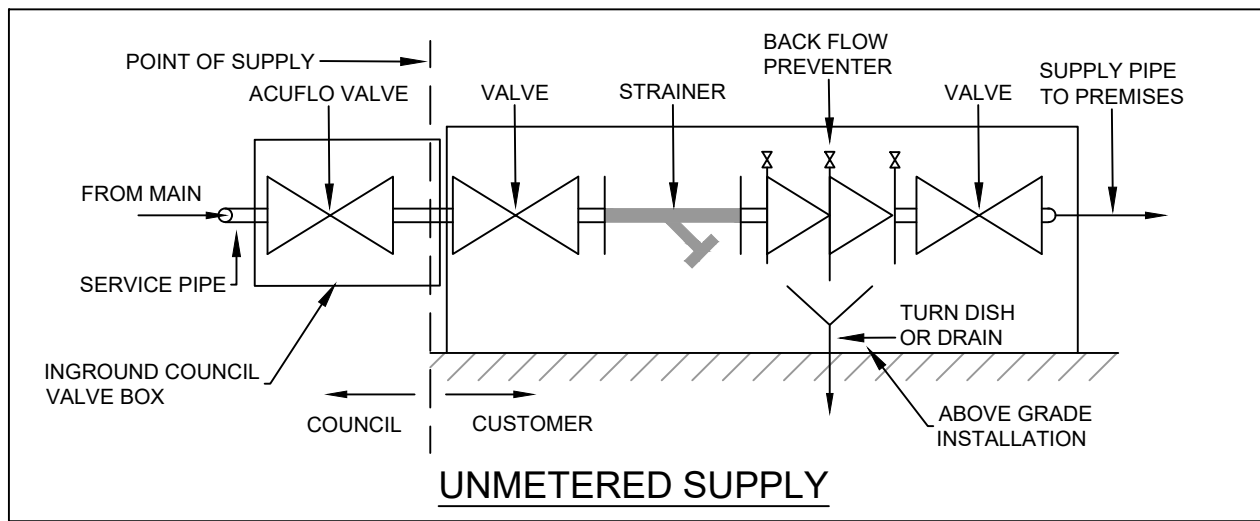

1. A STANDARD ACUFLO BOX AND MANIFOLD WILL NOT BE APPLICABLE TO THIS INSTALLATION. ACUFLO HARDWARE IS ONLY SUITABLE FOR UP TO 25mm PIPE CONNECTIONS. THIS INSTALLATION WILL NEED TO BE CONFIGURED SPECIFIC TO THE SITE. REFER TO ITEMS BELOW THAT ARE MANDATORY:
 - THE SERVICE PIPE SHALL HAVE A BLUE RESILIENT SEATED SERVICE VALVE IN ITS OWN VALVE BOX.
 - A REDUCED PRESSURE ZONE BFP SHALL BE INSTALLED INSIDE THE BOUNDARY OF THE PRIVATE PROPERTY. IF THE WATER SUPPLY IS PROPOSED TO BE DIVIDED INTO MULTIPLE LINES TO SERVICE DIFFERENT AREAS OF THE SITE, THE BFP SHALL BE LOCATED ON THE SINGLE INCOMING WATER SUPPLY LINE IN ADVANCE OF ANY SUCH DIVISION. A RPZ SHALL BE LOCATED ABOVE GROUND.
 - THIS BFP IS THE POS BFP DEVICE REQUIRED BY THE HEALTH AMENDMENT ACT 2007. THE DEVICE SHALL BE LOCATED IN AN ABOVE GROUND ENCLOSURE WHERE POSSIBLE.

LOCATING BACK FLOW PREVENTERS AND WATER METERS

2. BACK FLOW PREVENTERS SHALL BE LOCATED DIRECTLY WITHIN THE ROAD FRONTAGE BOUNDARY OF THE PROPERTY SERVED IN EVERY INSTANCE EXCEPT WHERE IN A CBD ENVIRONMENT WHERE THERE MAY BE NO SPACE WITHIN THE BUILDING FRONTAGE FOR AN ABOVE GROUND CABINET.
3. A BFP SHALL BE INSTALLED IN ACCORDANCE WITH THE MANUFACTURER RECOMMENDATIONS, AND THE APPROPRIATE BFP USED SHOULD BE DETERMINED BASED ON THE HAZARD. IF USING A RPZ BFP, IT SHALL BE INSTALLED ABOVE GROUND. ALL OTHER BFP'S SHOULD BE ABOVE GROUND WHERE POSSIBLE. THE BFP SHALL ALLOW ANY WATER DISCHARGED TO DRAIN TO GROUND IN AN OBVIOUS MANNER.
4. THE FIRST ISOLATION VALVE IS THE SUPPLY POINT; THIS IS THE BOUNDARY BETWEEN COUNCIL RESPONSIBILITY AND PRIVATE OWNER'S RESPONSIBILITY FOR SERVICE AND WATER QUALITY.
5. THE ISOLATION VALVE SHALL BE LOCATED ON THE ROAD RESERVE IN ALL INSTANCES AND SHALL NOT BE LOCATED ON A ROW OR EASEMENT.

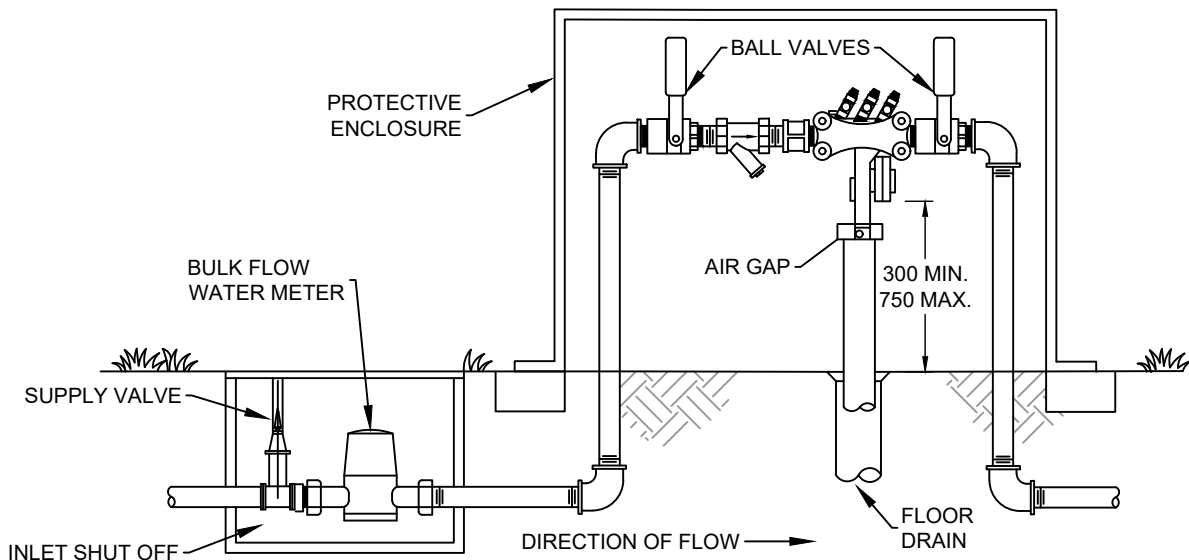
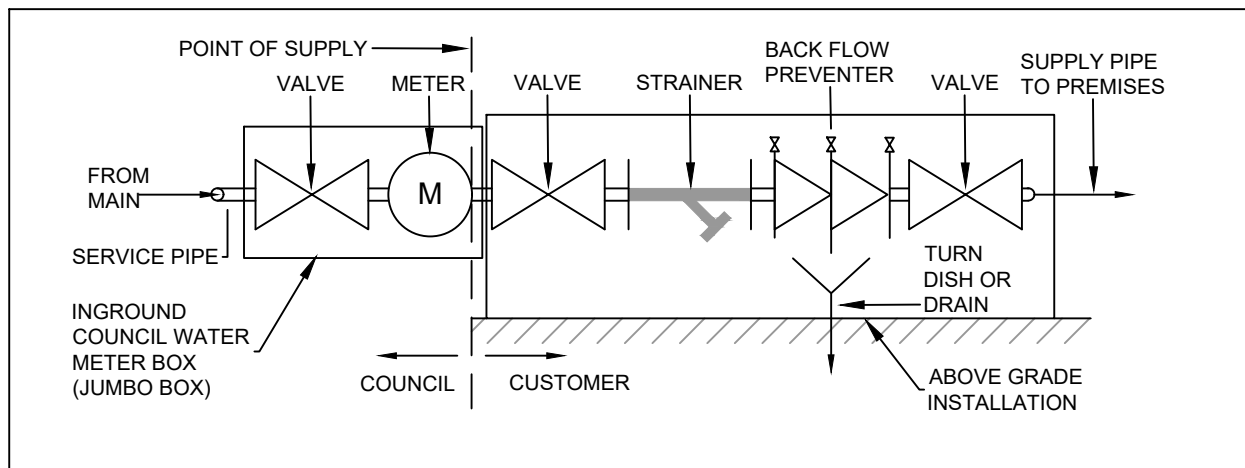

1. A STANDARD ACUFLO BOX AND MANIFOLD WILL NOT BE APPLICABLE TO THIS INSTALLATION. ACUFLO HARDWARE IS ONLY SUITABLE FOR UP TO 25mm PIPE CONNECTIONS. THIS INSTALLATION WILL NEED TO BE CONFIGURED SPECIFIC TO THE SITE. REFER TO ITEMS BELOW THAT ARE MANDATORY:
 - THE SERVICE PIPE SHALL HAVE A BLUE RESILIENT SEATED SERVICE VALVE IN ITS OWN VALVE BOX PRIOR TO A WATER METER BOX.
 - A WATER METER BOX SHALL BE LOCATED 300mm BEFORE THE PRIVATE PROPERTY BOUNDARY. THE BOX SHALL CONTAIN AN APPROVED WATER METER OF A SUITABLE SIZE. THE METER SHALL HAVE THREE REGISTERS OF THE SUB m³ VALUES. THIS IS COUNCIL'S POINT OF SUPPLY BOUNDARY AND IS LOCATED IN THE STREET PRIOR TO THE REQUIRED BFP.
 - A BFP DEVICE OF EITHER RA TESTABLE DOUBLE CHECK VALVE ASSEMBLY OR REDUCED PRESSURE ZONE BFP SHALL BE INSTALLED INSIDE THE BOUNDARY OF THE PRIVATE PROPERTY. IF THE WATER SUPPLY IS PROPOSED TO BE DIVIDED INTO MULTIPLE LINES TO SERVICE DIFFERENT AREAS OF THE SITE, THE BFP SHALL BE LOCATED ON THE SINGLE INCOMING WATER SUPPLY LINE IN ADVANCE OF ANY SUCH DIVISION.
 - THIS BFP IS THE POS BFP DEVICE REQUIRED BY THE HEALTH AMENDMENT ACT 2007. IF THIS DEVICE IS ASSESSED TO BE A RPZ THEN IT SHOULD BE LOCATED IN AN ABOVE GROUND ENCLOSURE.
 - AN **ELSTER HELIX 4000 OR C4000 / 4200 OR SENSUS MEITWIN; MEISTREAM; WP** WATER METER SHALL BE INSTALLED ON TO THE MANIFOLD.
- LOCATING BACK FLOW PREVENTERS AND WATER METERS
2. BACK FLOW PREVENTERS SHALL BE LOCATED DIRECTLY WITHIN THE ROAD FRONTAGE BOUNDARY OF THE PROPERTY SERVED IN EVERY INSTANCE EXCEPT WHERE IN A CBD ENVIRONMENT WHERE THERE MAY BE NO SPACE WITHIN THE BUILDING FRONTAGE FOR AN ABOVE GROUND CABINET.
 3. THE BFP SHALL BE ABOVE GROUND AND ALLOW ANY WATER DISCHARGED TO DRAIN TO GROUND IN AN OBVIOUS MANNER. WHERE DOUBLE CHECK VALVE DEVICES ARE INSTALLED IN AN UNDERGROUND CHAMBER, THE DESIGN MUST ALLOW FOR SERVICING BY TOP ENTRY AND THE CHAMBER MUST BE WELL DRAINED. FOR LARGER SIZED DOUBLE CHECK VALVE DEVICES IT IS GOOD PRACTICE TO INSTALL THESE ABOVE GROUND, FOR EASE OF ACCESS AND POSSIBLE FUTURE UPGRADING TO REDUCED PRESSURE ZONE DEVICES.
 4. THE WATER METER IS THE SUPPLY POINT; THIS IS THE BOUNDARY BETWEEN COUNCIL RESPONSIBILITY AND PRIVATE OWNER'S RESPONSIBILITY FOR SERVICE AND WATER QUALITY.
 5. THE WATER METER SHALL BE LOCATED ON THE ROAD IN ALL INSTANCES AND SHALL NOT BE LOCATED ON A ROW OR EASEMENT.
 6. WATER METERS OF SIZES LARGER THAN 25mm WILL REQUIRE A JUMBO METER BOX AND A SEPARATE INDIVIDUAL TOBY VALVE WITH VALVE CHAMBER PRIOR TO THE WATER METER BOX.
 7. THE WATER METER BOX SHALL HAVE THE WORDS "METER" AND/OR "WATER METER" VISIBLE UPON THE COVER.

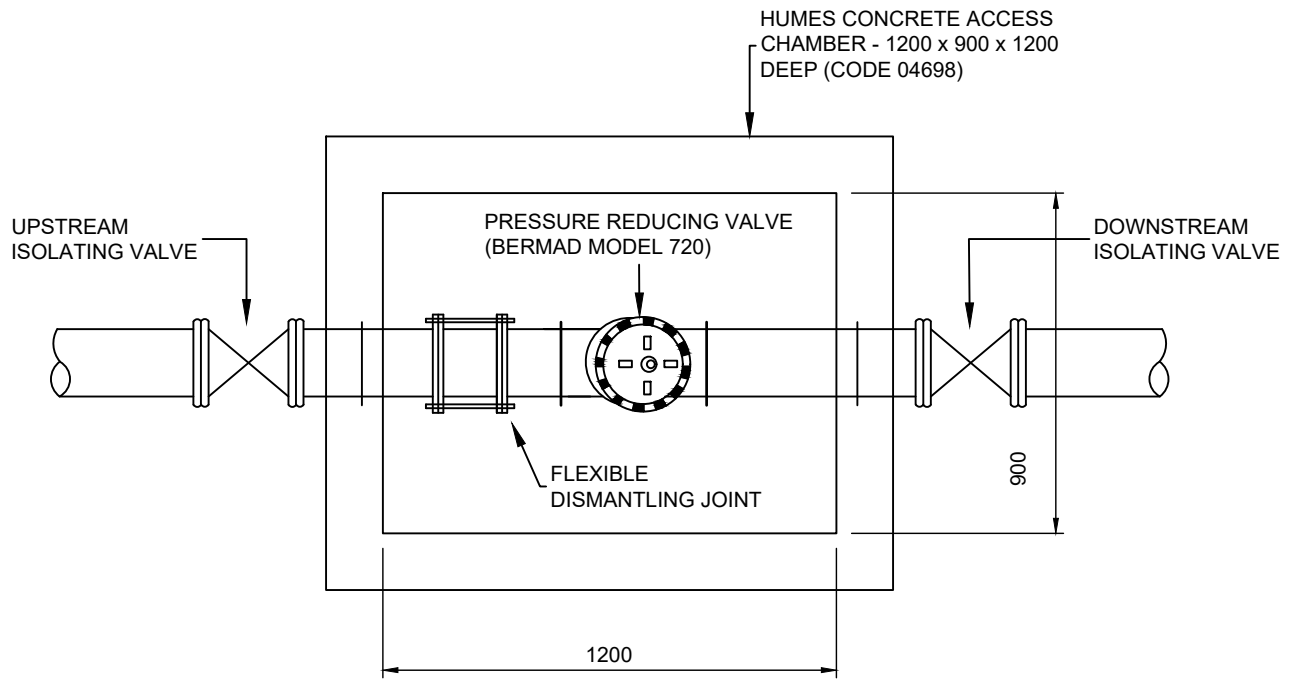

PLAN

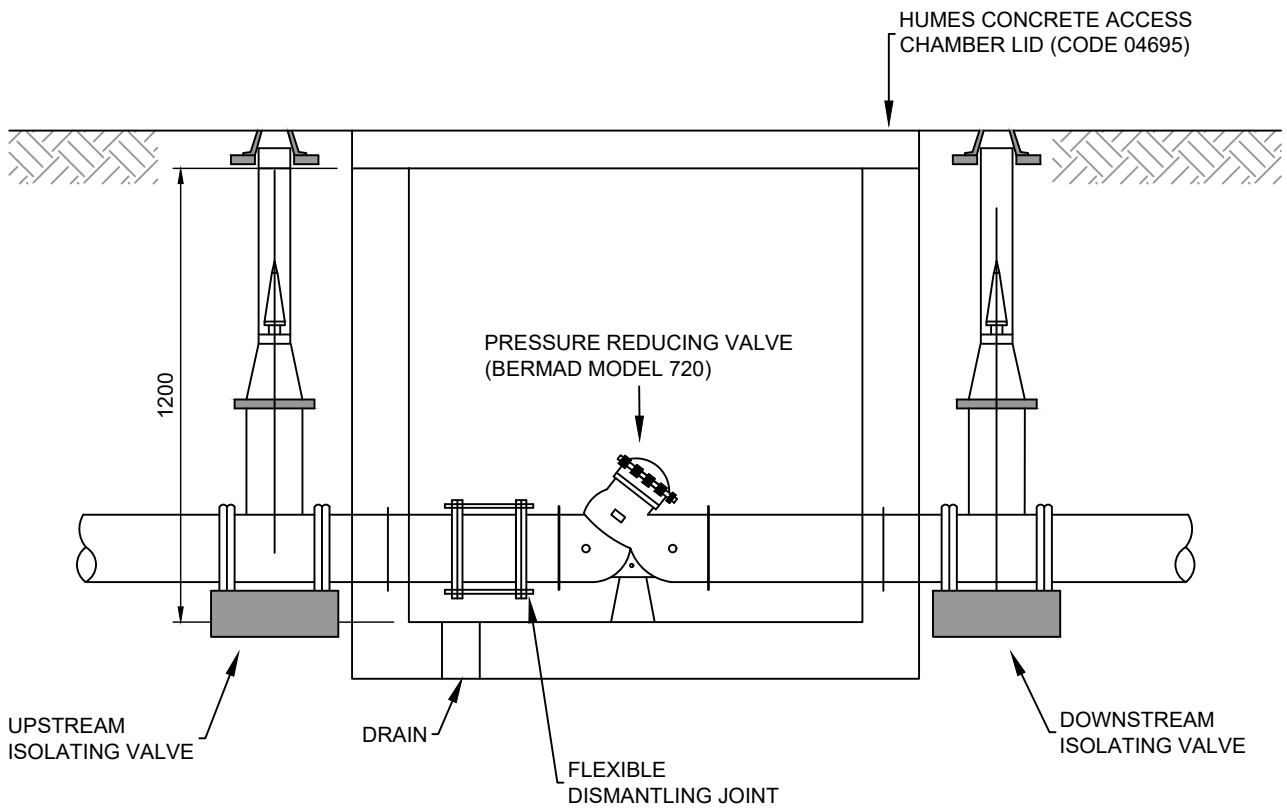

SECTION

NOTES:

1. CONSIDERATION NEEDS TO BE GIVEN FOR UPSTREAM FILTER AND PRESSURE RELIEF VALVE WHEN DESIGNING THE INSTALLATION OF THESE VALVES.
2. CONSIDERATION NEEDS TO BE GIVEN FOR DRAINAGE WITHIN THE VALVE CHAMBER.

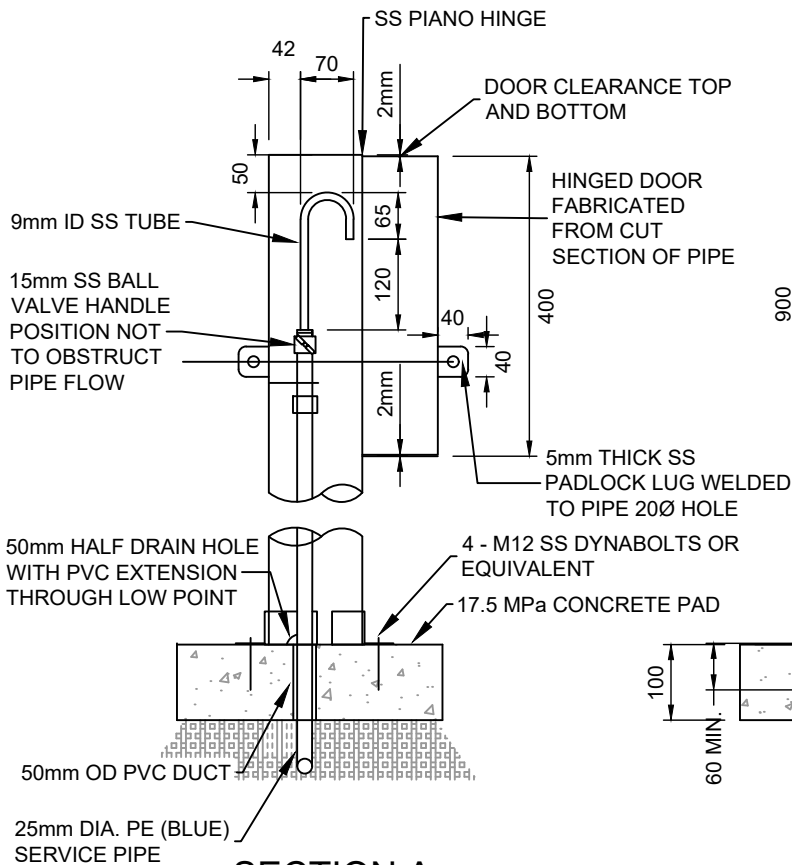

SECTION A

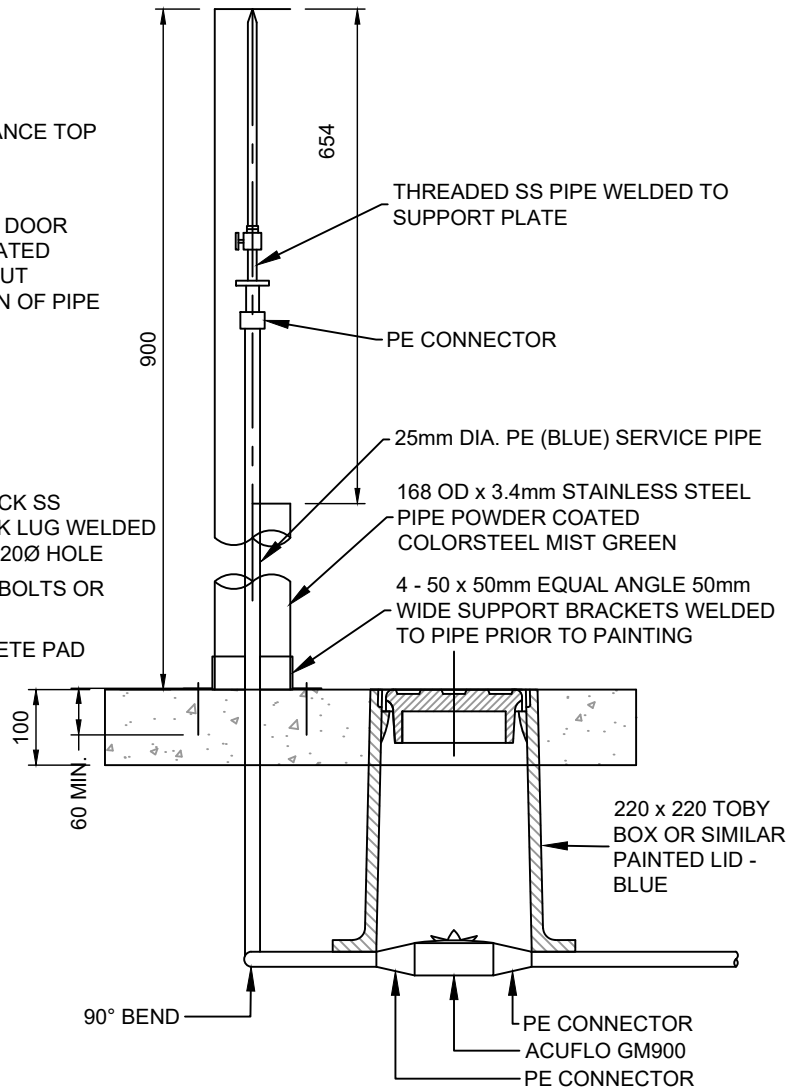

SECTION B

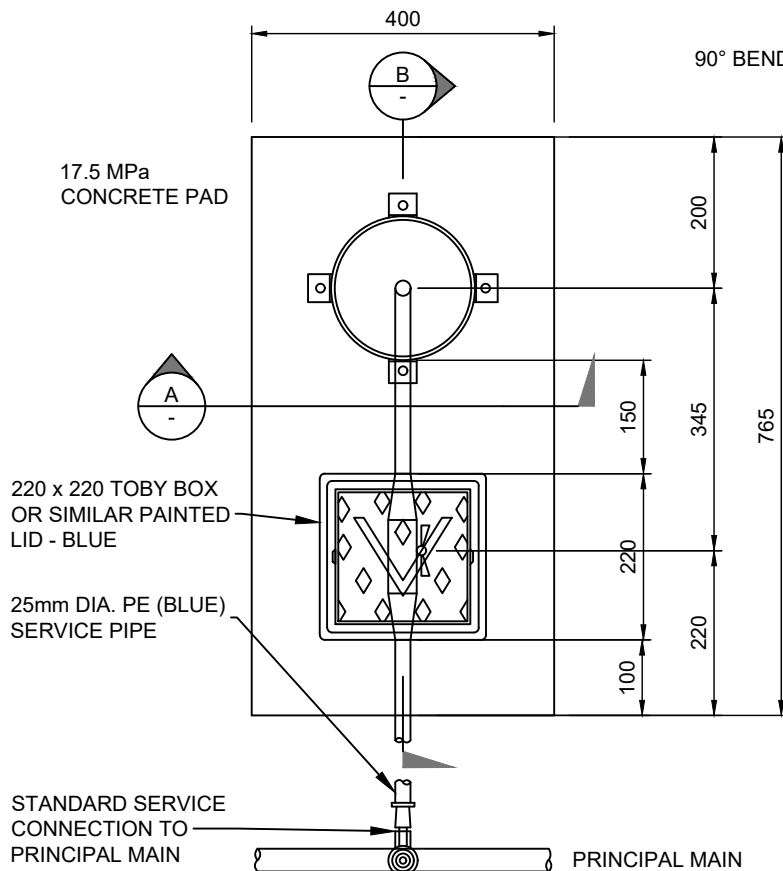

PLAN

NOTES

1. THIS ARRANGEMENT IS TO BE USED FOR ALL SAMPLING POINTS IN THE DISTRIBUTION NETWORK.
2. ALL PE CONNECTORS TO BE EITHER PUSHLOK, PLASSON, PHILMAC OR SIMILAR APPROVED.
3. ON SLOPING GROUND INSTALL DOOR OPENING ON UPHILL SIDE.
4. ALL WELDS TO BE 4mm FILLET.

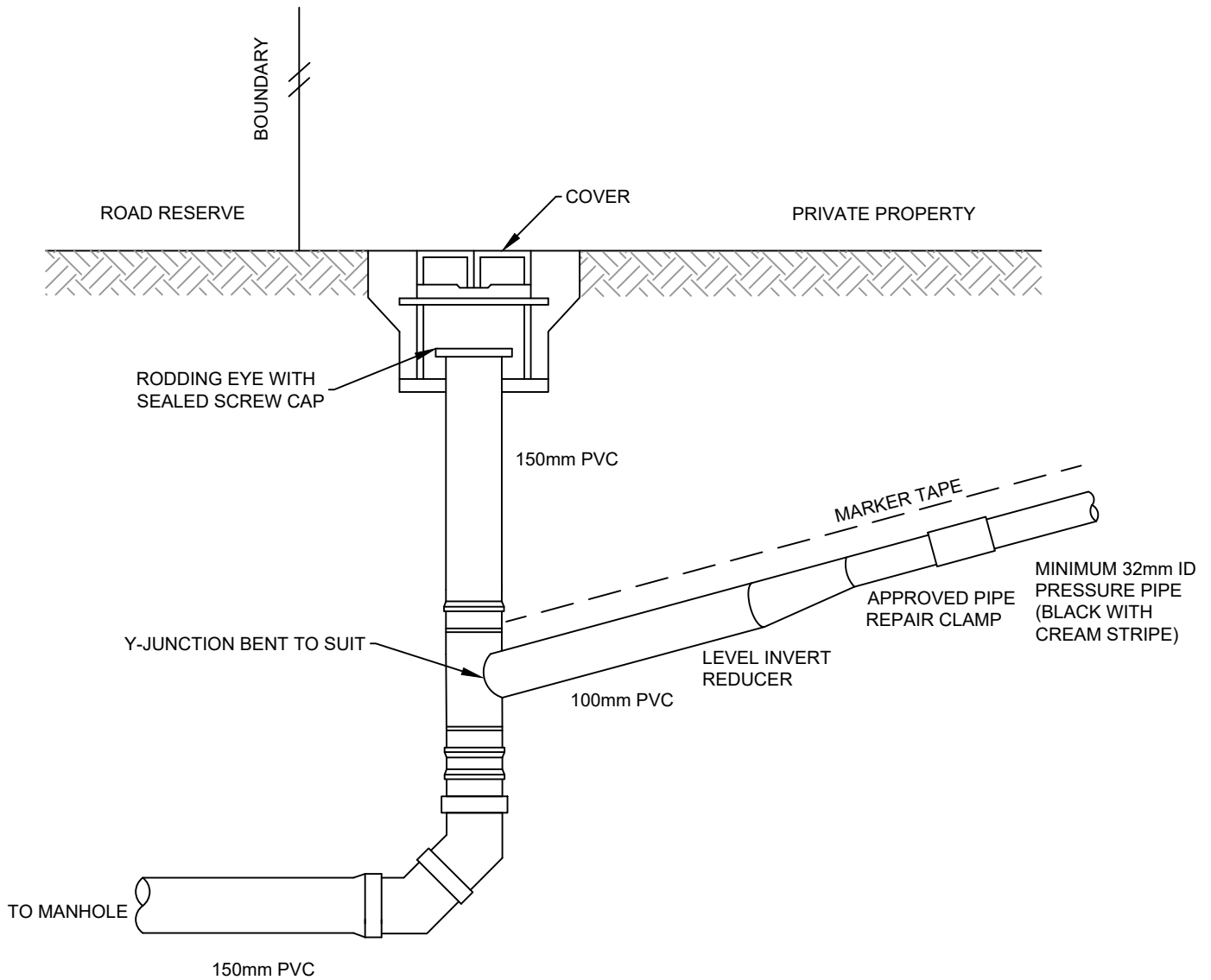

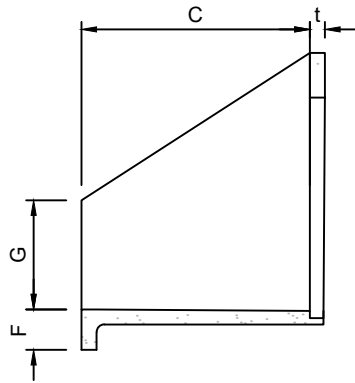

CROSS SECTION A

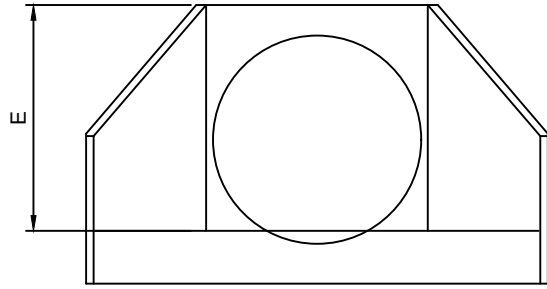

FRONT ELEVATION

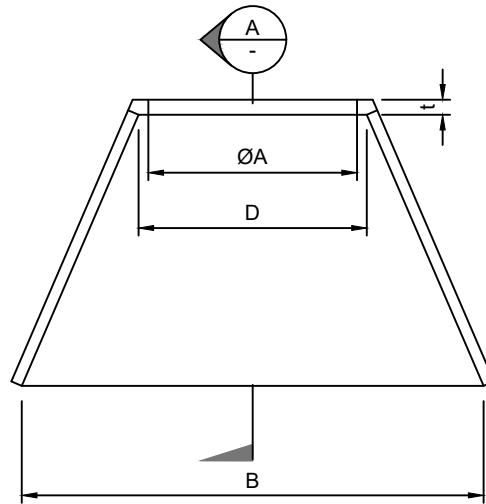

PLAN VIEW

TABLE 1

PIPE DIA.	PRINCIPAL DIMENSIONS (mm)							
	A	B	C	D	E	F	G	t
150-300	190-390	1000	600	460	520	200	160	50
300-600	370-700	1900	1100	750	900	280	500	80
600-1050	720-1225	3000	100	1270	1675	345	600	100
1200-1350	1380-1540	4100	2400	1600	1975	425	750	125
1600-1800	1727-2040	4900	2400	2150	2265	450	750	150

NOTES:

1. REINFORCED FLOOR AND WALLS WITH
150 TO 375 - 665 MESH (668 OR SIMILAR)
450 TO 600 - 663 MESH OR EQUIVALENT OR 10Ø RODS @ 250 CRS
675 TO 900 - 12Ø RODS @ 250 CRS
1050 TO 1350 - 12Ø RODS @ 150 CRS
2. ALL REINFORCEMENT SHALL BE PLACED CENTRAL IN WALLS & FLOOR AND SHALL BE CONTINUOUS BETWEEN WALL AND FLOOR.
3. LAPS IN STRUCTURAL GRADE BARS TO BE 300mm MINIMUM.
4. THERE SHALL BE AT LEAST TWO BARS WHETHER MESH OR MILD STEEL, OVER THE TOP OF THE PIPE.
5. CONCRETE COMPRESSIVE STRENGTH IS TO BE 20MPa @ 28 DAYS.
6. BAFFLES ARE TO BE CONSTRUCTED AS SHOWN WHEN OUTLET VELOCITIES AND SOIL CONDITIONS DICTATE. IN EXTREME CASES SPECIFIC DESIGN MAY BE REQUIRED.
7. INLETS EXCEEDING 450mmØ TO HAVE ANTI-VERMIN SCREENS FITTED, EXCEPT WHEN THE PIPE IS LESS THAN 20m LONG.
8. TABLE 1 IS FOR FORMING INLET AND OUTLET STRUCTURES OUTSIDE MANUFACTURERS SPECIFICATIONS.

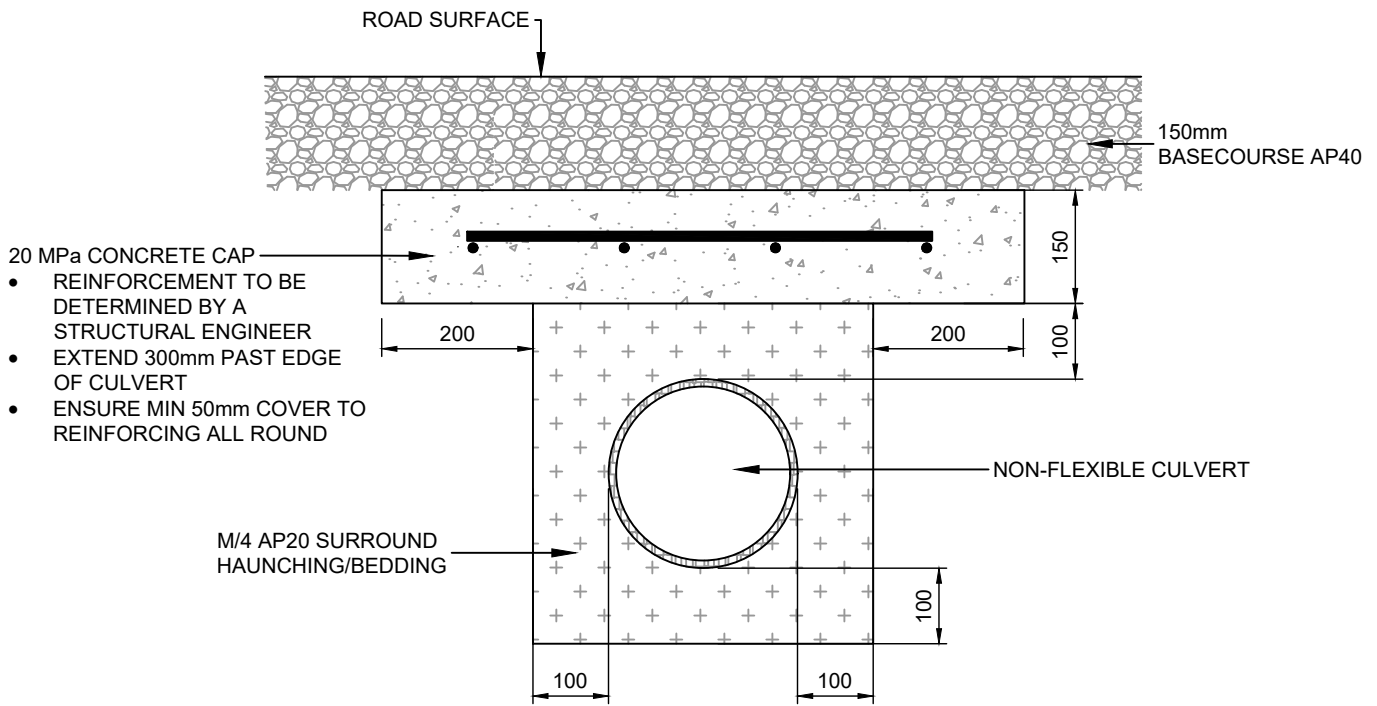

CONCRETE CAPPING DETAIL

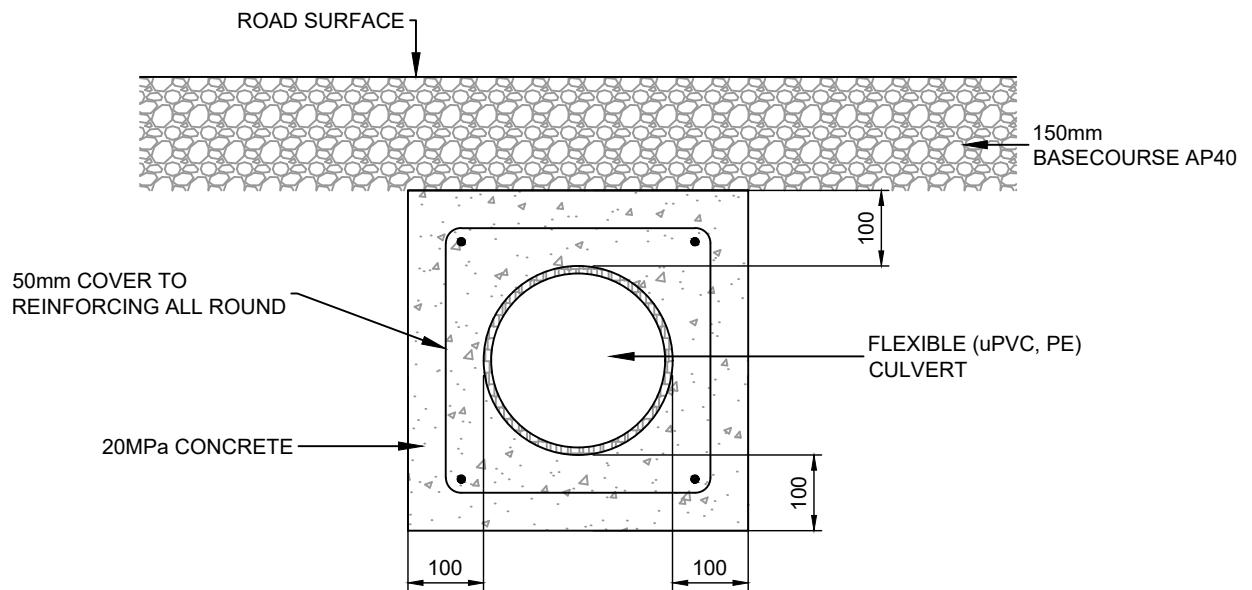

CONCRETE ENCASING DETAIL

NOTES:

- FOR NON-FLEXIBLE PIPE DIAMETERS GREATER THAN 450mm OR FLEXIBLE PIPE DIAMETERS GREATER THAN 300mm SPECIAL DESIGN APPLIES.
- WITH FLEXIBLE PIPES PROTECTION TO BE USED UNLESS OTHERWISE SPECIFIED.
- PIPES IN TRAFFICABLE AREAS WITH LESS THAN 1.0 m COVER SHALL BE CONCRETE CAPPED, AND PIPES WITH LESS 0.6 m COVER SHALL BE CONCRETE ENCASED. THE CONCRETE ENCASEMENT SHALL BE REINFORCED CONCRETE AND STRUCTURALLY DESIGNED FOR REQUIRED DESIGN LOAD BY A STRUCTURAL ENGINEER.

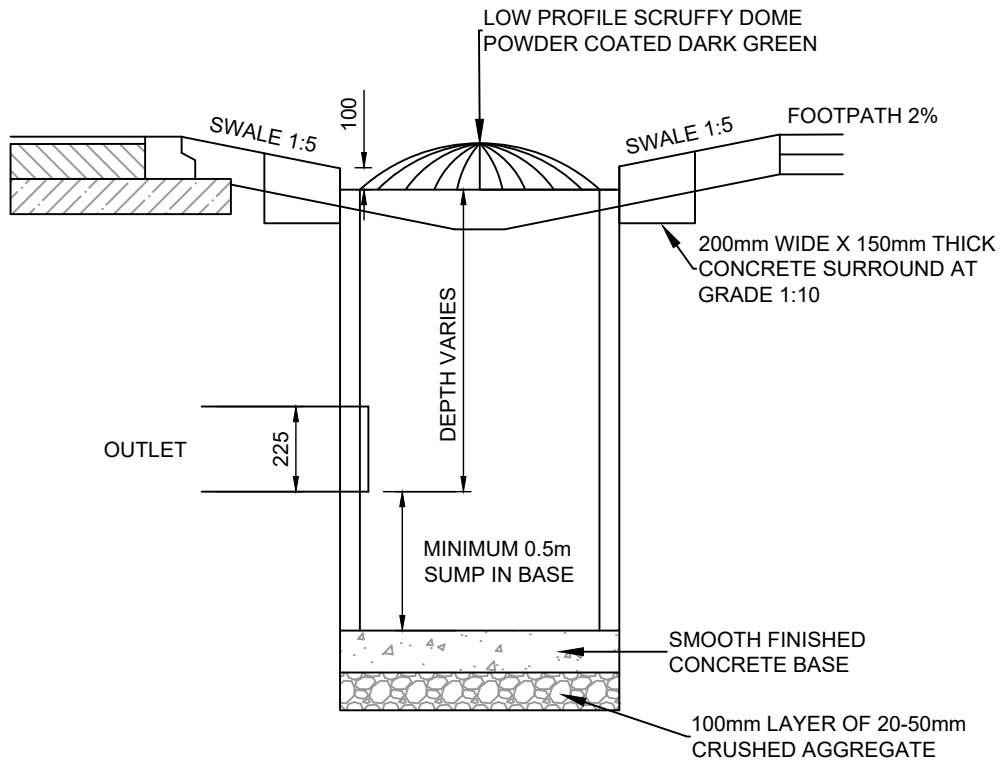

SIDE ELEVATION

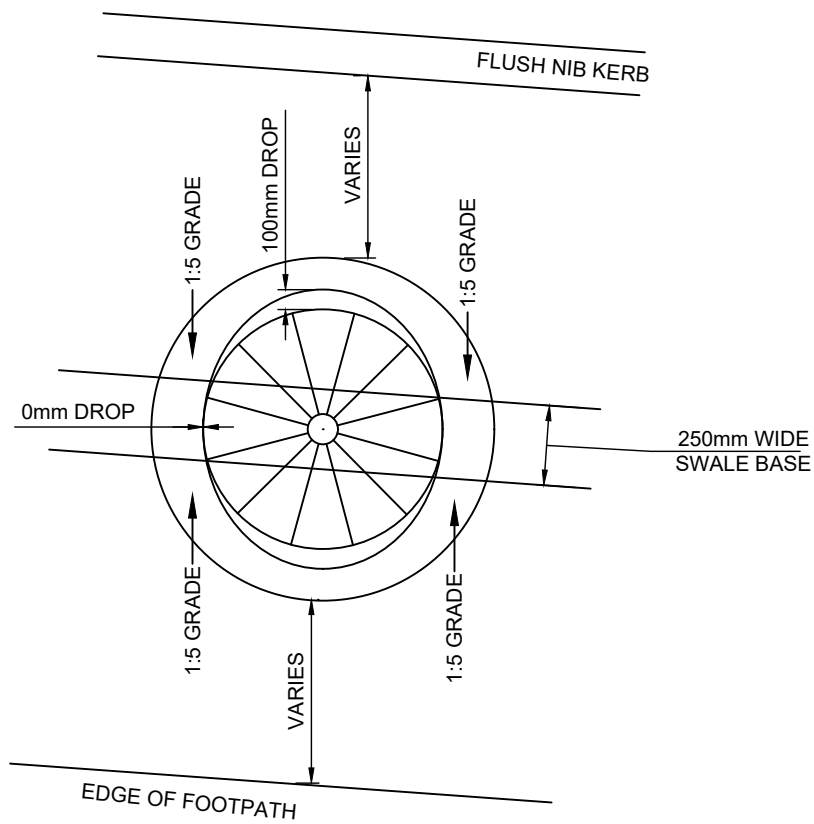

PLAN

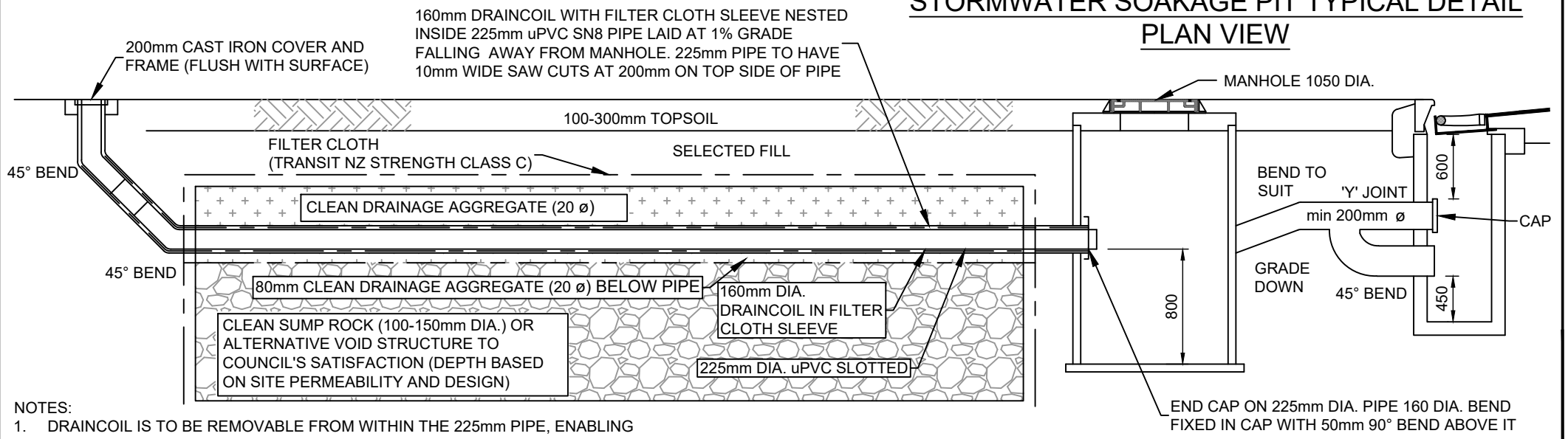
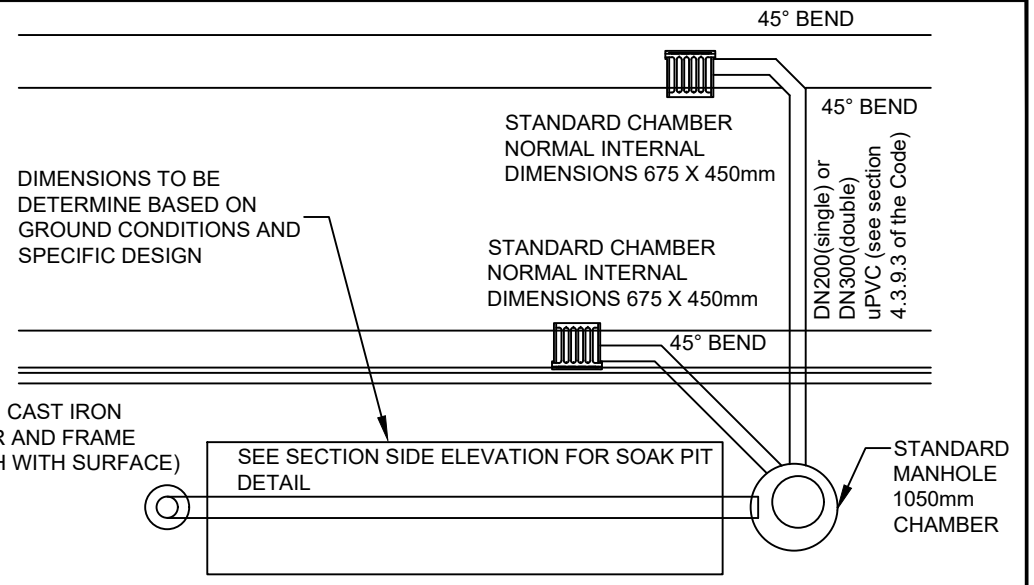
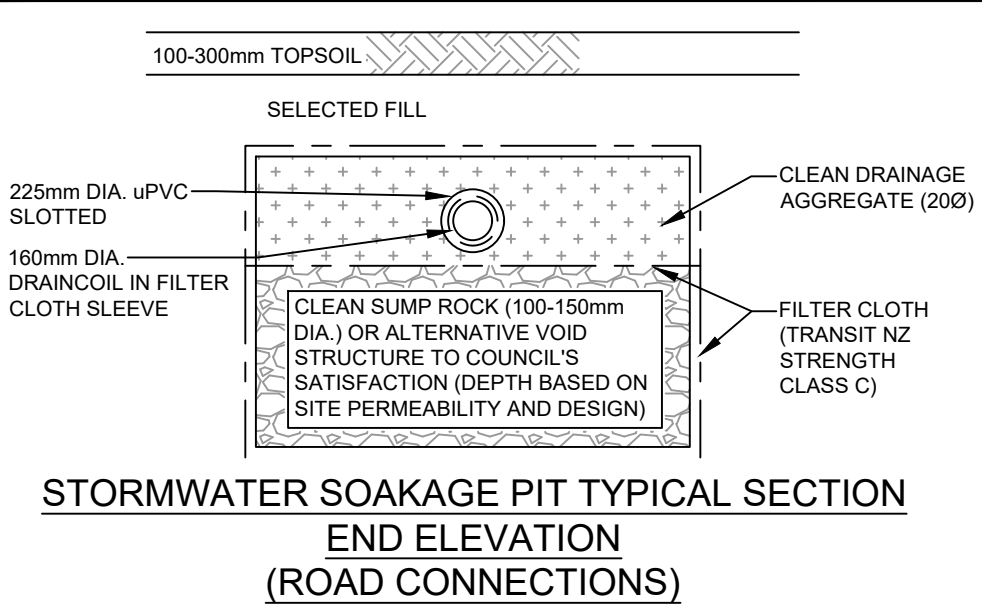

- NOTES:
1. DRAINCOIL IS TO BE REMOVABLE FROM WITHIN THE 225mm PIPE, ENABLING CLEANING/REPLACEMENT OF THE PIPE AND FILTER SLEEVE AS REQUIRED. CLEANING EYE ALLOWS FOR FLUSHING FROM EITHER END OF THE SYSTEM.
 2. SOAKPIT DIMENSIONS TO BE DETERMINED BASED ON GROUND CONDITIONS AND SPECIFIC DESIGN.

STORMWATER SOAKAGE PIT TYPICAL SECTION SIDE ELEVATION (ROAD CONNECTIONS)

QLD LDC 2020 Standard Details Revision: Rev Date:	Drawing Title: Synergy12d\123428_cab9a10a-0601-4c5f-b317-9d3d55824b7d	<h2>Soak Pit</h2>	NOT TO SCALE Drawing No. <h2>B4-4</h2>
---	--	-------------------	--

RADIUS TABLE	
RESIDENTIAL	---- 10 m
COMMERCIAL	---- 15 m
INDUSTRIAL	---- 15 m

DOUBLE SUMPS
WHERE CUL-DE-SAC
HEAD IN LOW POINT

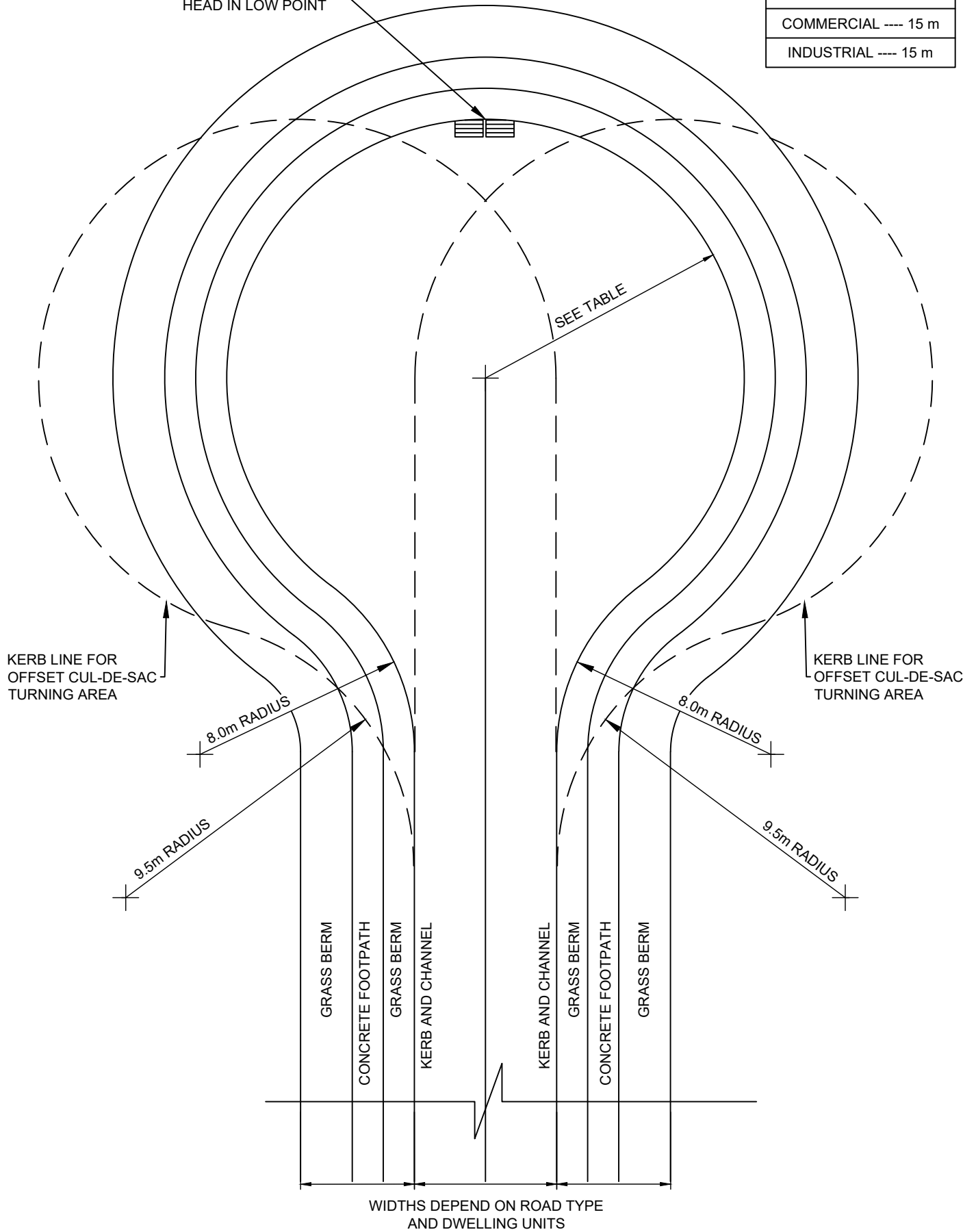

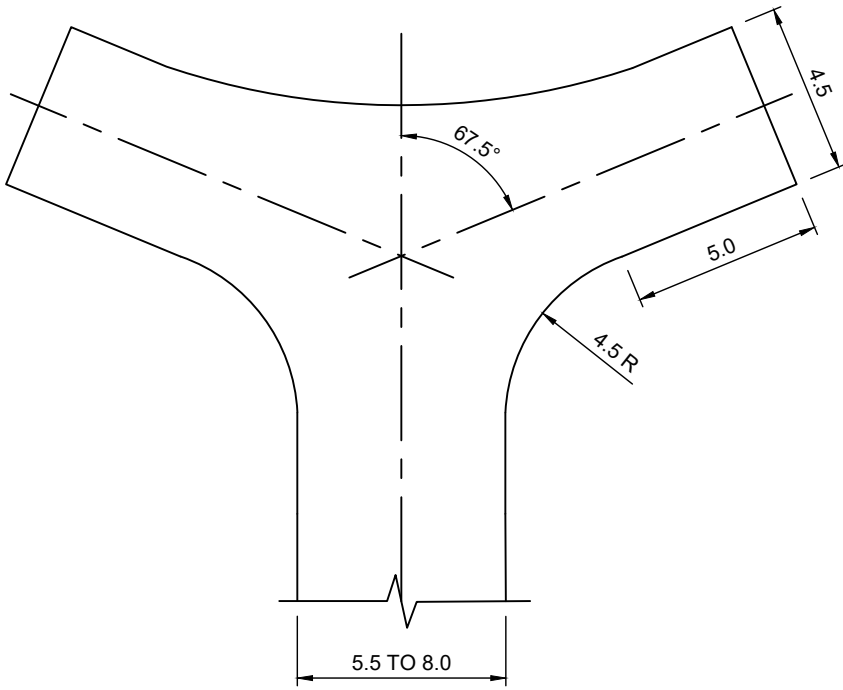

Y TURNING

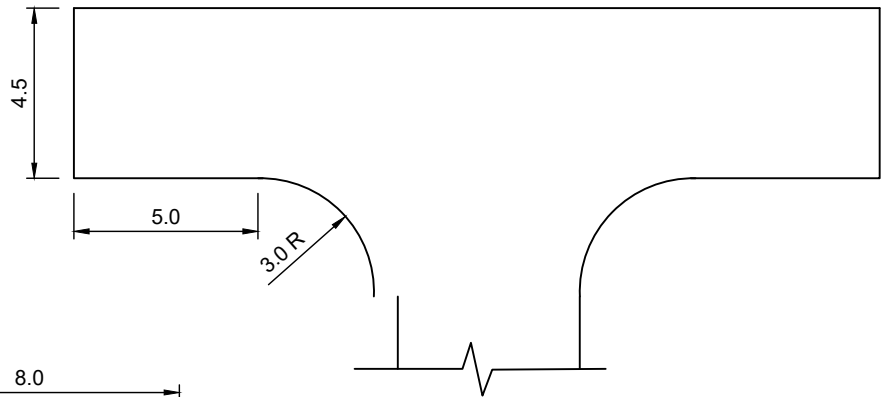

T TURNING

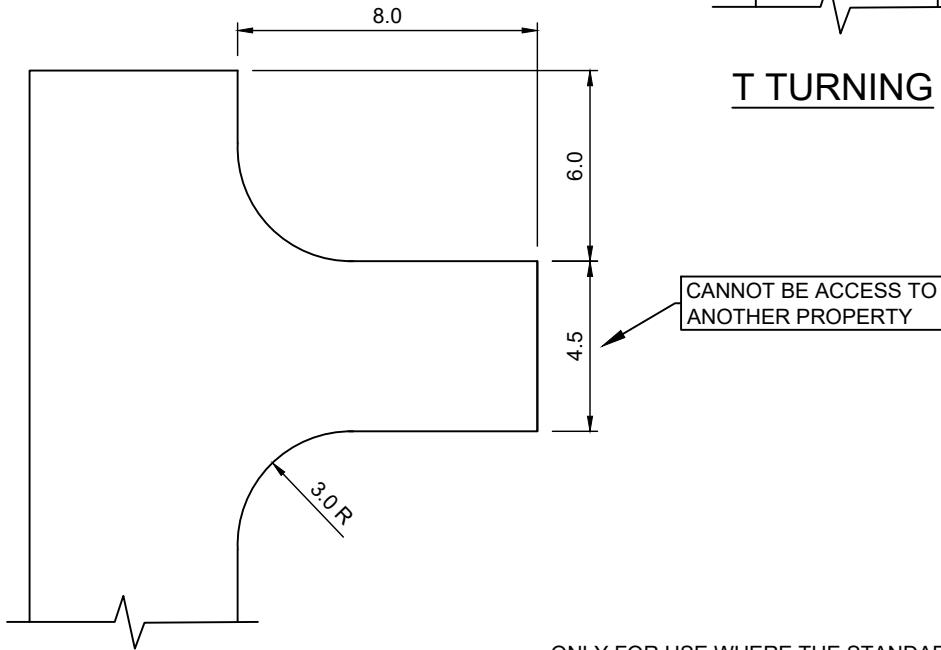

L TURNING

ONLY FOR USE WHERE THE STANDARD CIRCULAR HEAD IS UNSUITABLE OR WHERE APPROVED BY COUNCIL.

ALL DIMENSIONS ARE IN METRES.

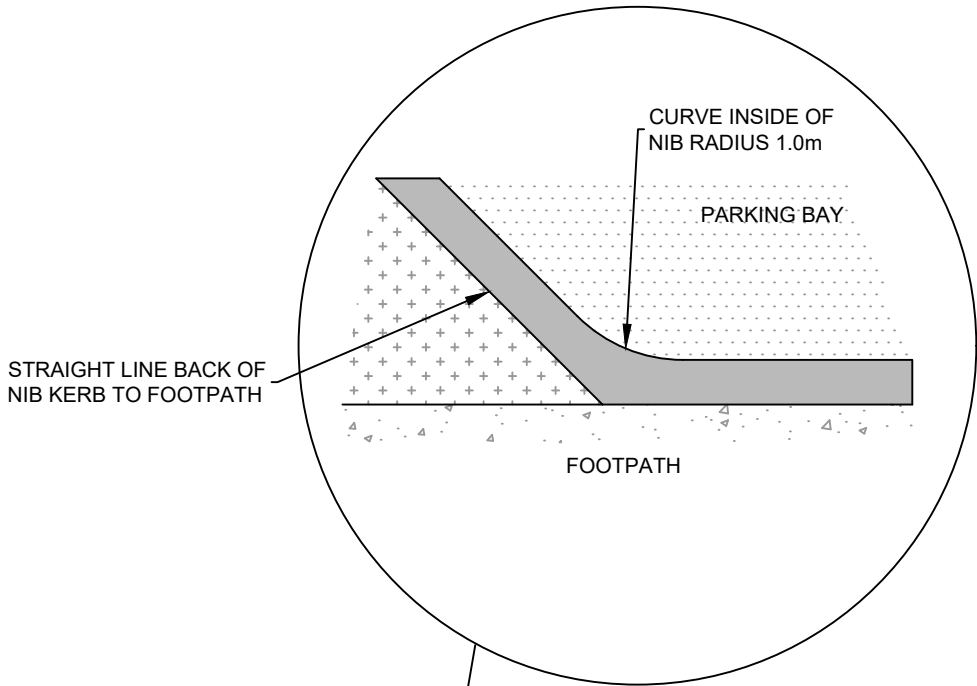

30mm ASPHALT OR 150mm CONCRETE
 REINFORCED WITH 665 MESH CENTRALLY
 PLACED OVER 150mm MINIMUM
 COMPACTED DEPTH OF AP40

3mm EXPANSION
 JOINT FOR
 CONCRETE

3mm EXPANSION
 JOINT FOR CONCRETE

NO 3 SLIP FORM KERB 100mm
 PROUD OF CAR PARK

NO 1 KERB
 AND
 CHANNEL

NO 2 VEHICLE CROSSING / CUTDOWN KERB

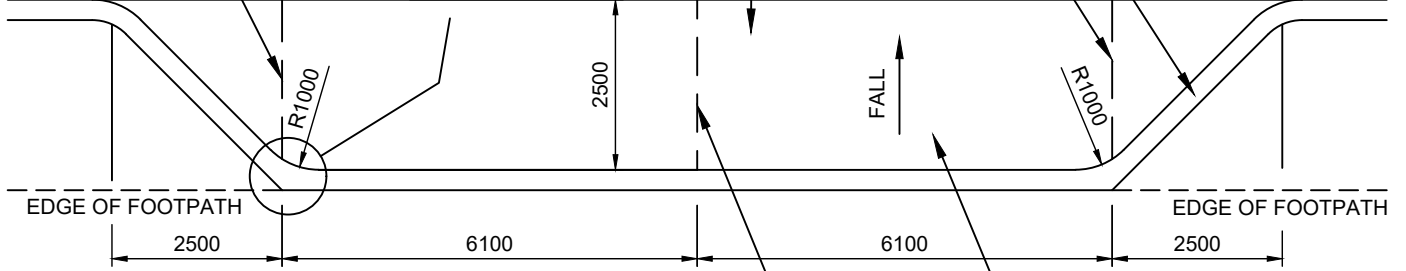

3mm EXPANSION
 JOINT FOR
 CONCRETE

4% FOR CHIP SEAL OR 3%
 FOR ASPHALT/CONCRETE

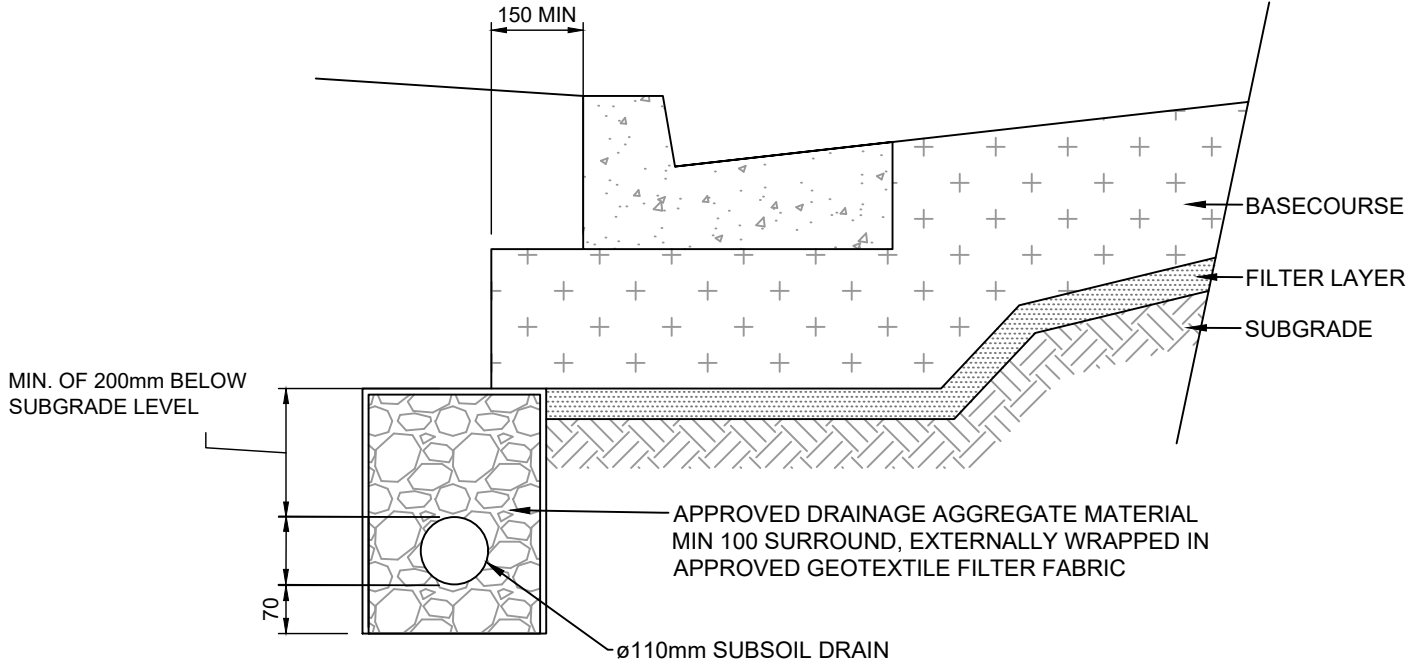

UNDER KERB DRAINAGE

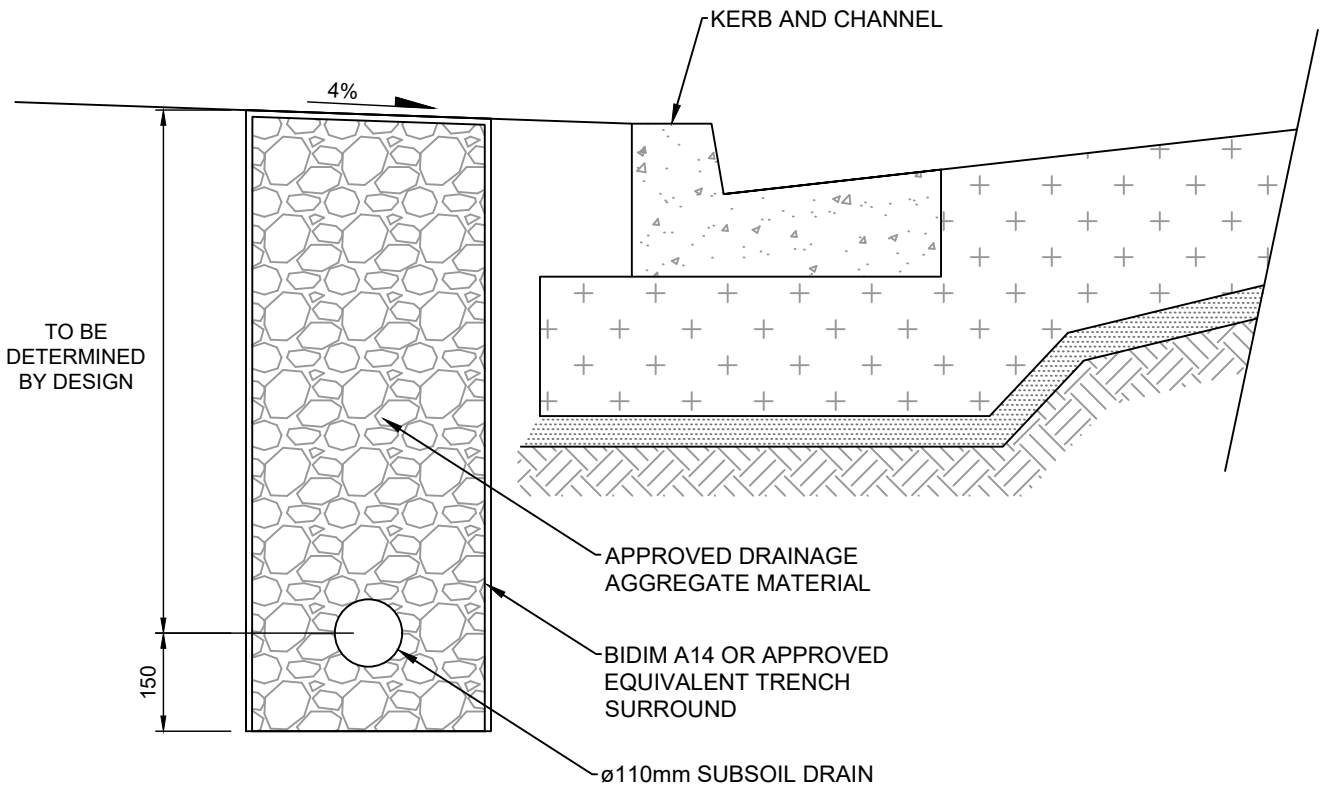

SURFACE WATER CUT-OFF DRAIN

ALL DIMENSIONS ARE IN MILLIMETRES

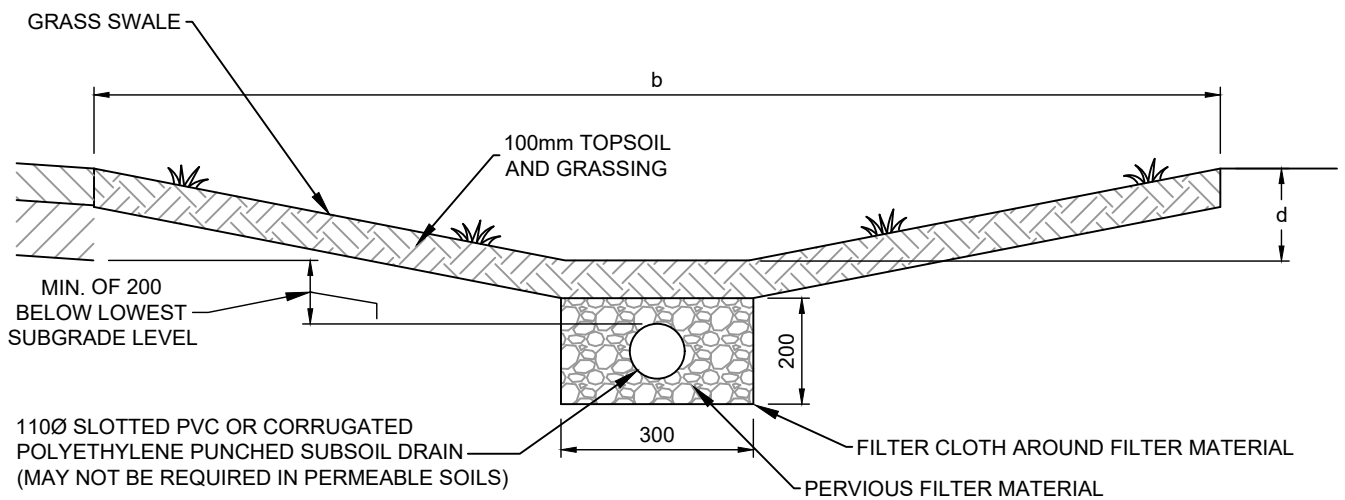

SWALE CROSS SECTION

NOTES:

1. EFFECTIVE CATCHMENT AREA DRAINED = IMPERVIOUS AREA + 0.72 x PERVIOUS AREA.
2. MAXIMUM SWALE SLOPE UP TO 5%. STEEPER SWALES REQUIRE CHECK DAMS (SEE DRAWING B5-6 AND DRAWING B5-7).
3. DIMENSIONS 'b' AND 'd' TO BE SIZED FOR CONVEYANCE OF 5% AEP EVENT.
4. EXISTING GROUND IS REGRADED, COMPACTED, TOPSOILED (100mm DEPTH), AND GRASSED.
5. SIDE SLOPES NO STEEPER THAN 1v:4h IF PLANTED (NOT MOWN).
6. SIDE SLOPES NO STEEPER THAN 1v:5h IF GRASSED (MOWN).

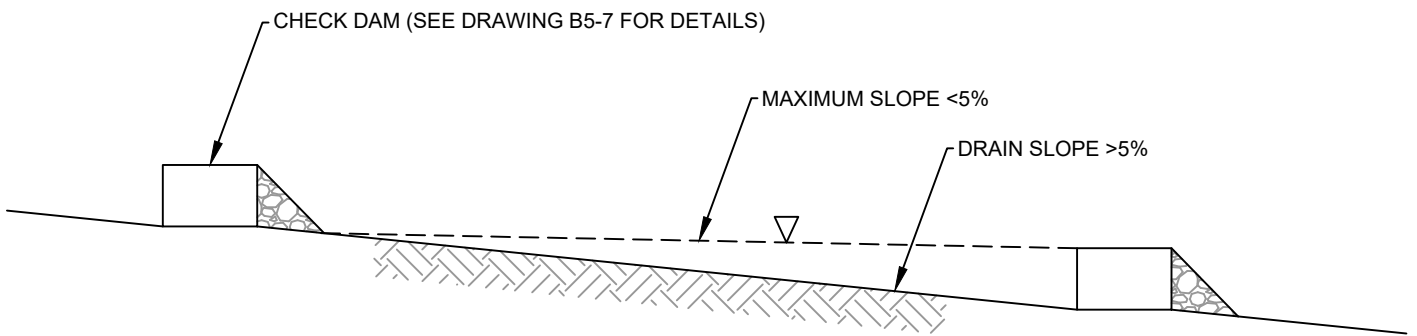

LOCATION OF CHECK DAMS IN SWALES

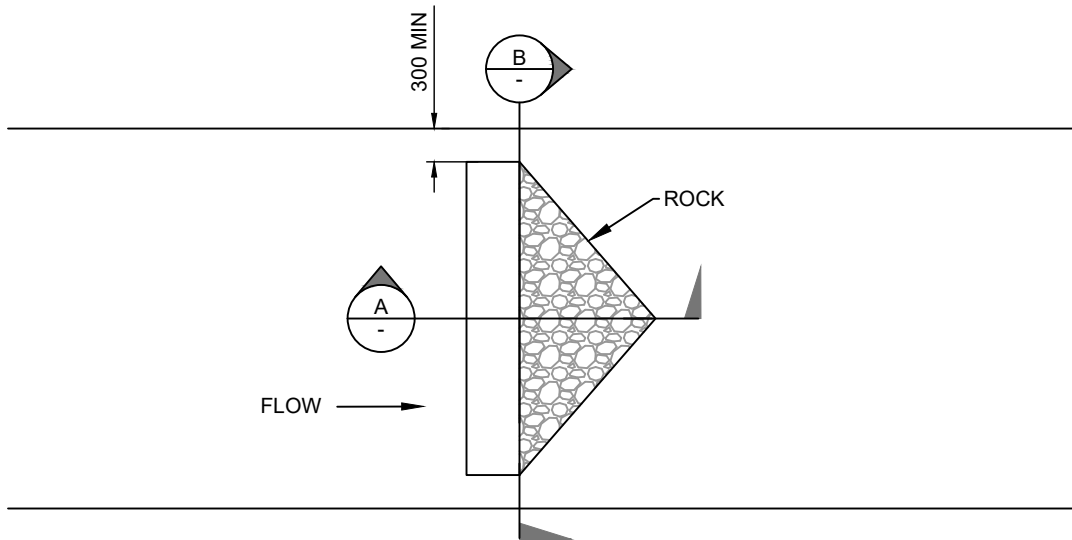

TYPICAL PLAN

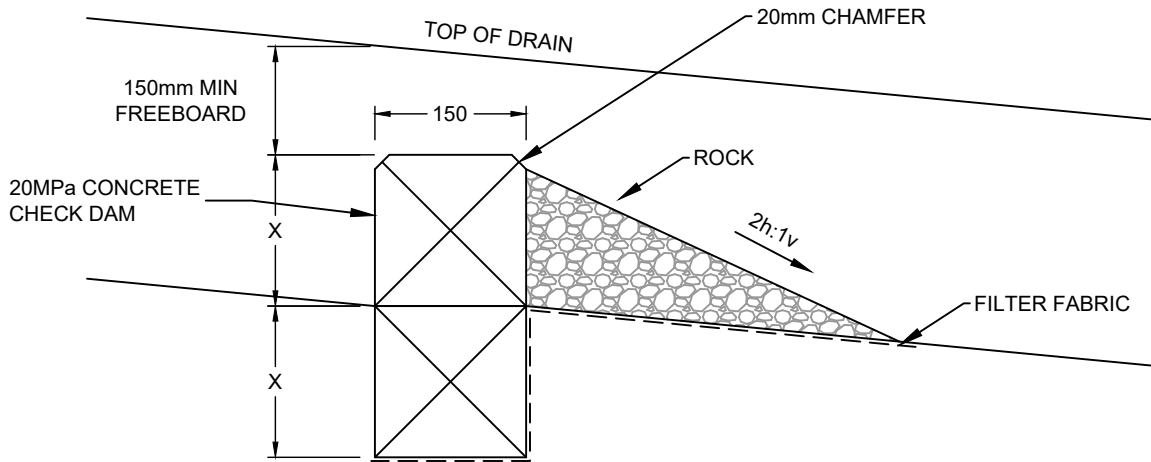

ELEVATION A

ROCK TO BE SCORIA GRADED CLEAN (SGC) 75-70 OR EQUIVALENT.
 FILTER FABRIC TO BE BIDIM A14 OR EQUIVALENT.

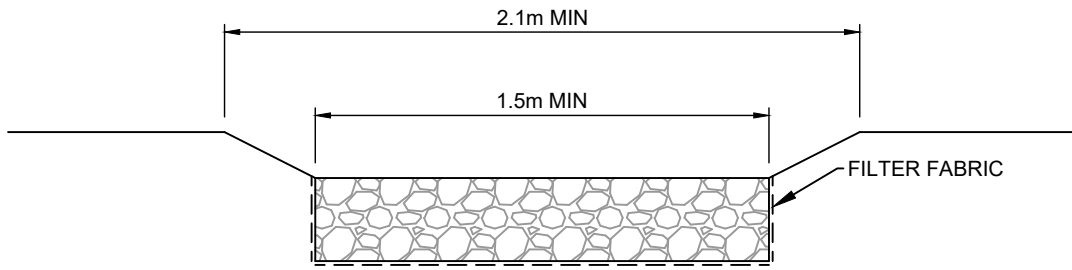

ELEVATION B

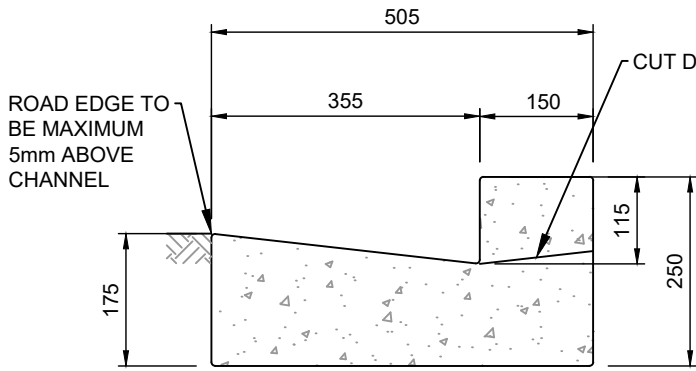

No. 1 KERB & CHANNEL

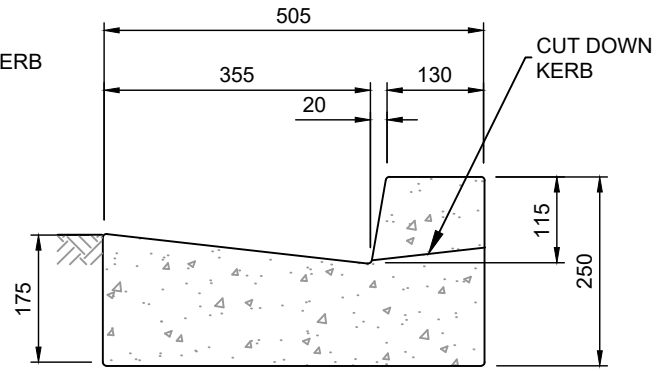

No. 1a KERB & CHANNEL

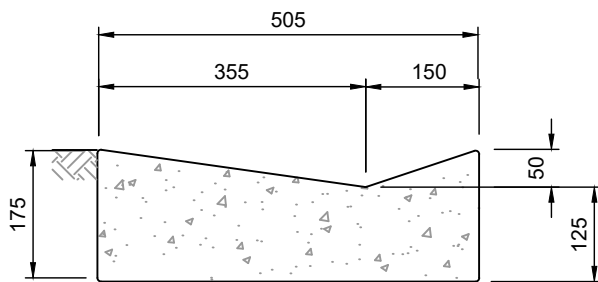

No. 2 VEHICLE CROSSING

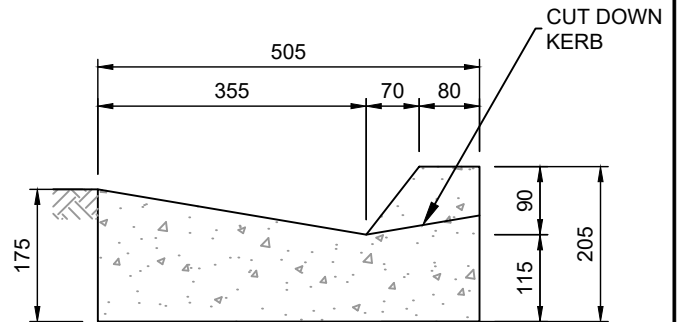

No. 8 MOUNTABLE KERB & CHANNEL

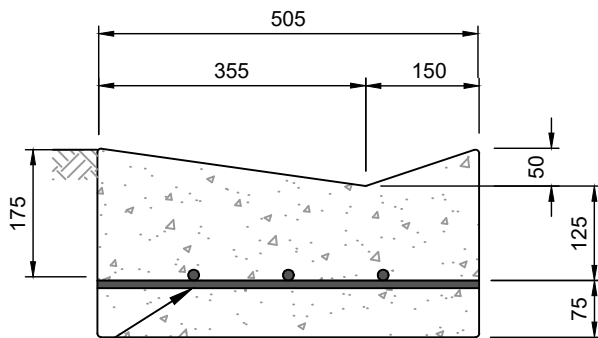

No. 2a COMMERCIAL VEHICLE CROSSING

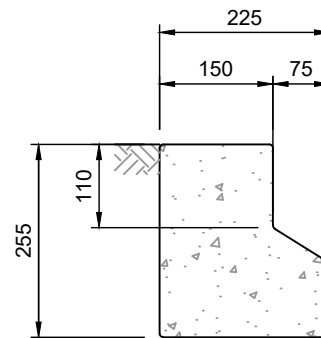

No. 3 SLIP FORM KERB

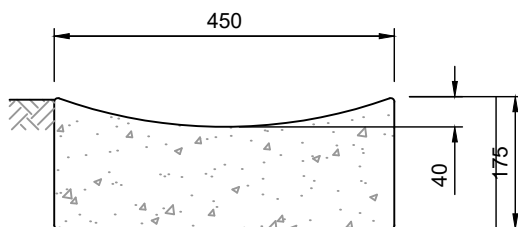

No. 16 DISH CHANNEL

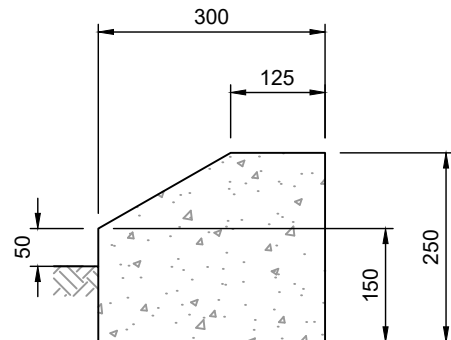

No. 5 MOUNTABLE KERB

NOTE: KERB AND CHANNELS TO HAVE 200mm MIN. DEPTH OF COMPACTED AP40 BASECOURSE OR GAP65 SUBBASE UNDER THEM

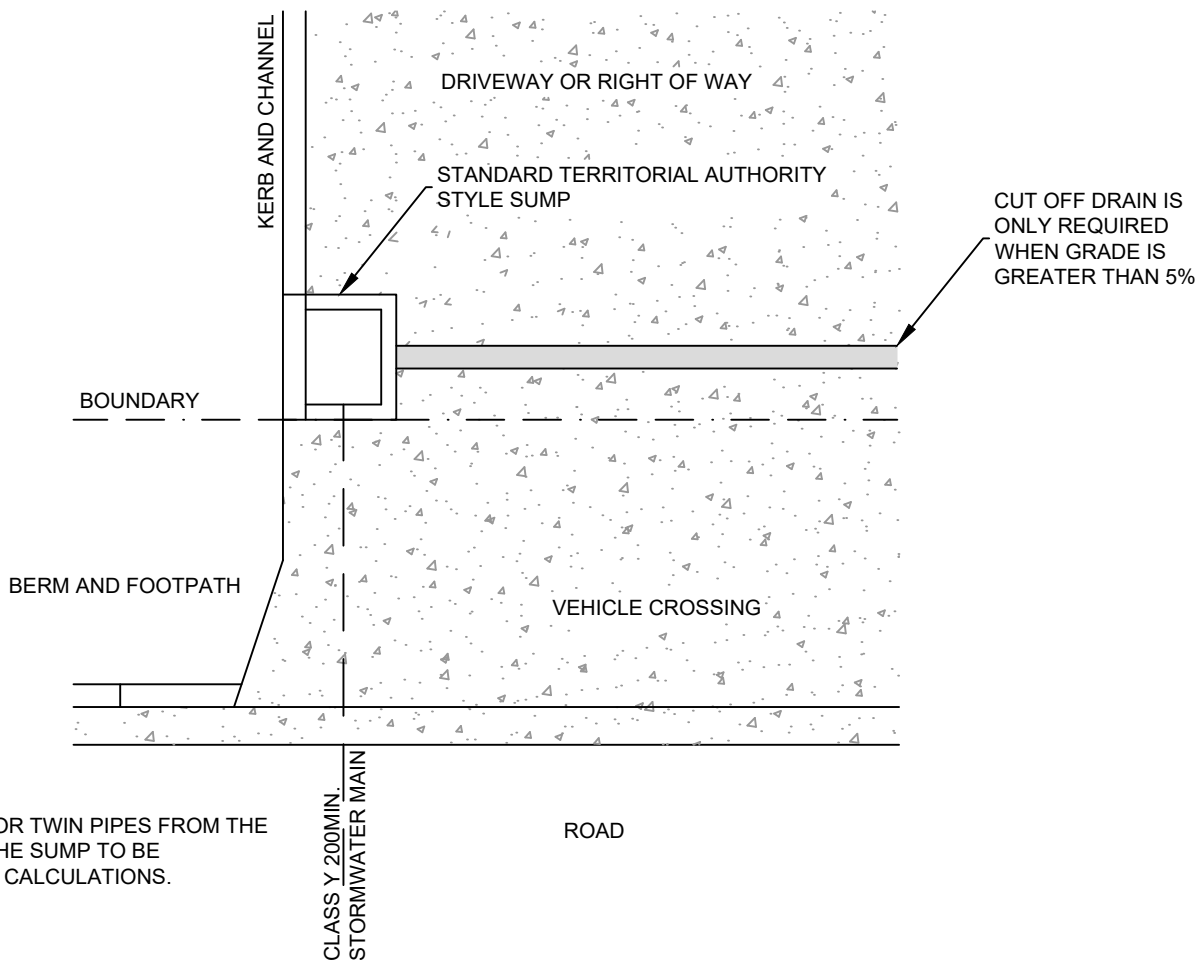

NOTES:
 1. USE OF SINGLE OR TWIN PIPES FROM THE PROPERTY TO THE SUMP TO BE DETERMINED BY CALCULATIONS.

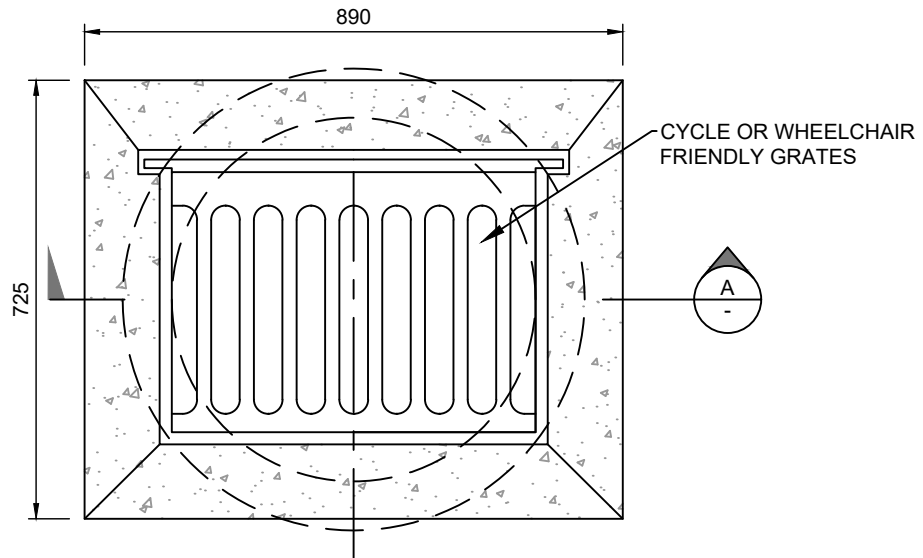

PLAN

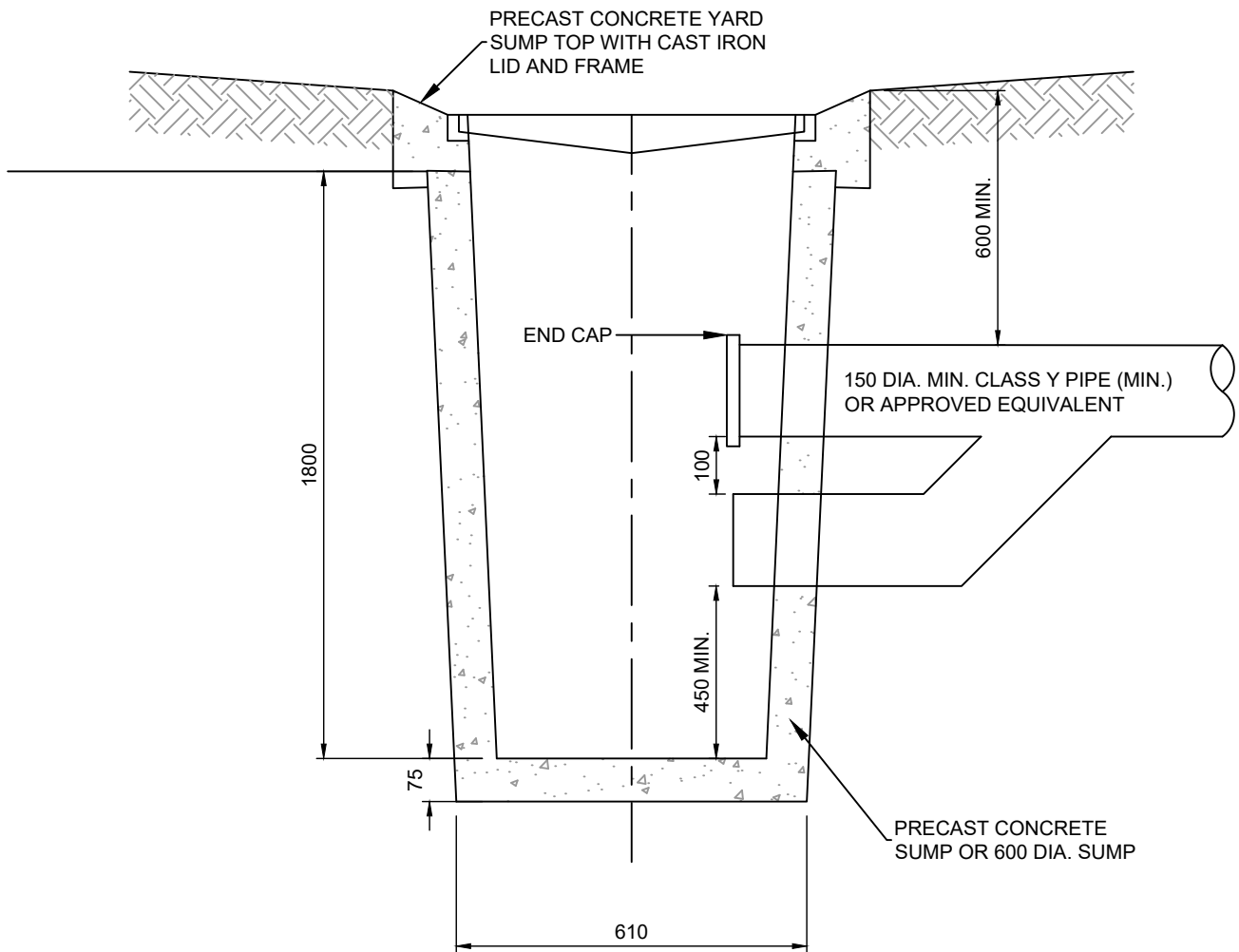

SECTION A

NOTE:

1. SUMP OUTLET MAY BE 150 DIA. IN PRIVATE PROPERTY
2. ALL DIMENSIONS ARE IN MILLIMETRES

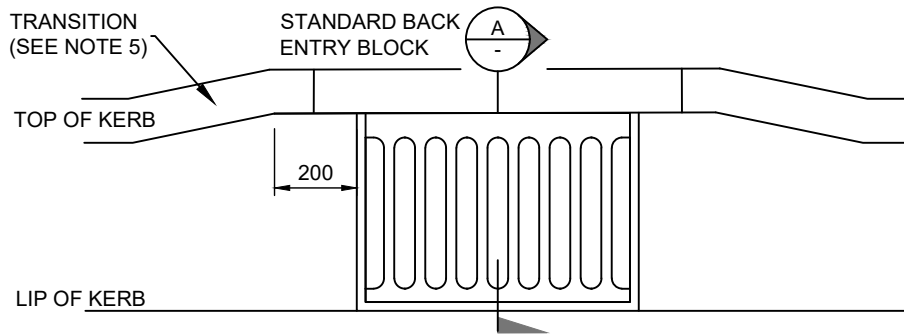

STANDARD SUMP IN CHANNEL

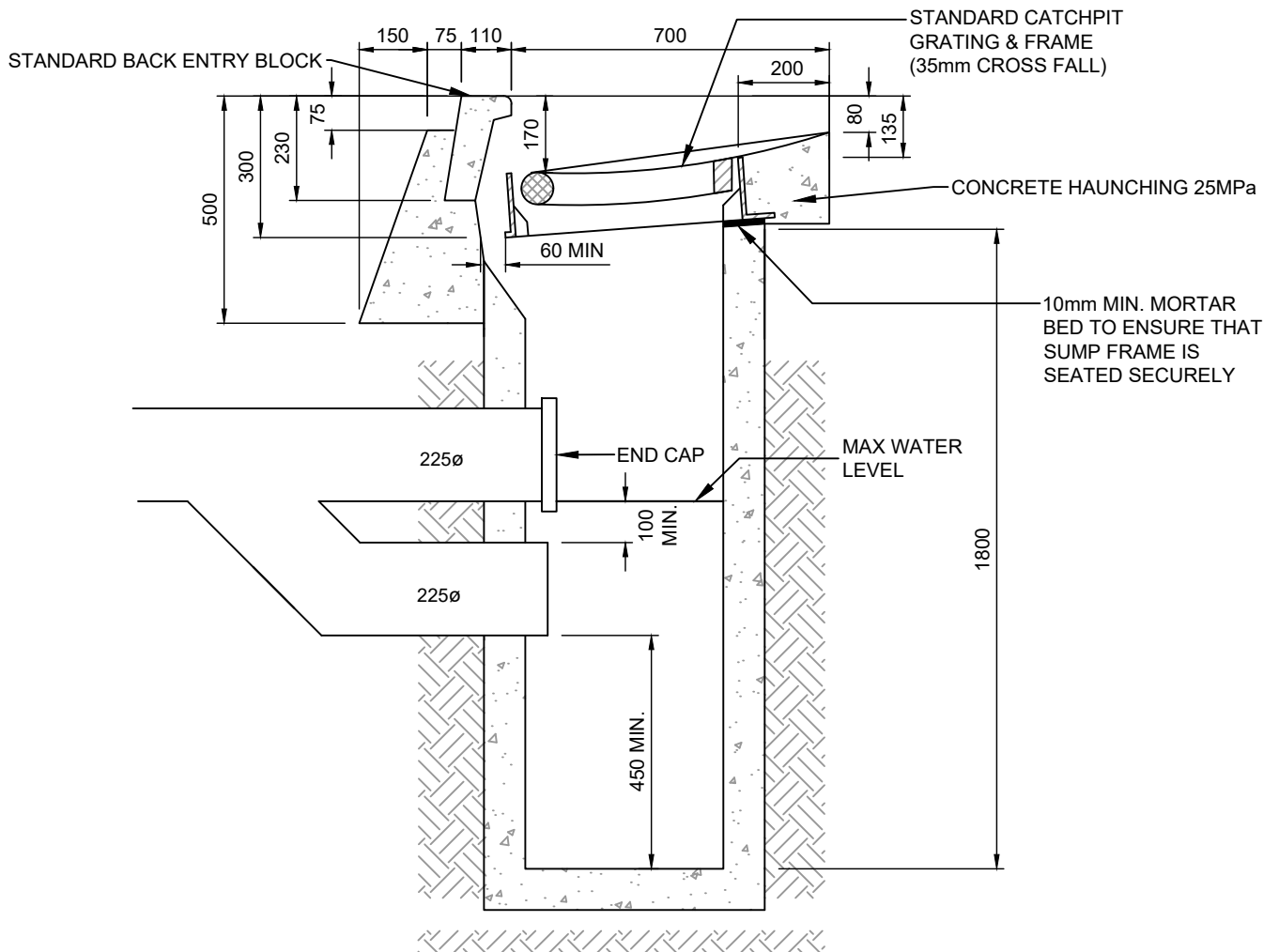

SECTION A

NOTE:

1. ROAD SUMPS TO BE PLACED AT 90m (MAX.) INTERVALS.
2. DOUBLE SUMPS TO BE INSTALLED IN PLACE OF SINGLE SUMPS:
 - A. UNDER VERTICAL CURVES IN ROADS
 - B. ON ALL ROADS WITH VERTICAL GRADIENTS EXCEEDING 10%.
SPECIFIC DESIGN REQUIRED WHERE GRADIENT EXCEEDS 12%.
3. SUMP LEADS TO INTERSECT SIDE OR BACKWALL OF SUMP BOX AT 90°.
4. SITE-SPECIFIC DESIGN REQUIRED TO REDUCE SYPHON FROM 225ø DOWN TO 150ø.
5. WHERE GRADIENTS EXCEED 10%, CHANNEL TRANSITION INTO DOUBLE MUDTANK TO BE 800mm AND CHANNEL TO BE FORMED DIRECTLY INTO BACK ENTRY.
6. TO BE USED WHERE BACK OF KERB IS NOT DIRECTLY ADJACENT TO THE FOOTPATH.
7. ALL SUMPS SHOULD BE 1800mm DEPTH.
8. A MINIMUM SEDIMENT STORAGE DEPTH OF 450mm IS TO BE PROVIDED (TO INVERT OF PIPE).
9. REDUCED COVER WHERE THE LEADS LEAVE THE MUD SUMP IS ACCEPTABLE. THIS SHOULD NOT REDUCE BELOW A MINIMUM OF 600mm COVER TO PIPE.
10. THE LENGTH OF PIPE WITH REDUCED COVER SHOULD BE MINIMISED AND AVOID EXTENDING INTO THE WHEEL TRACKS AS FAR AS POSSIBLE.

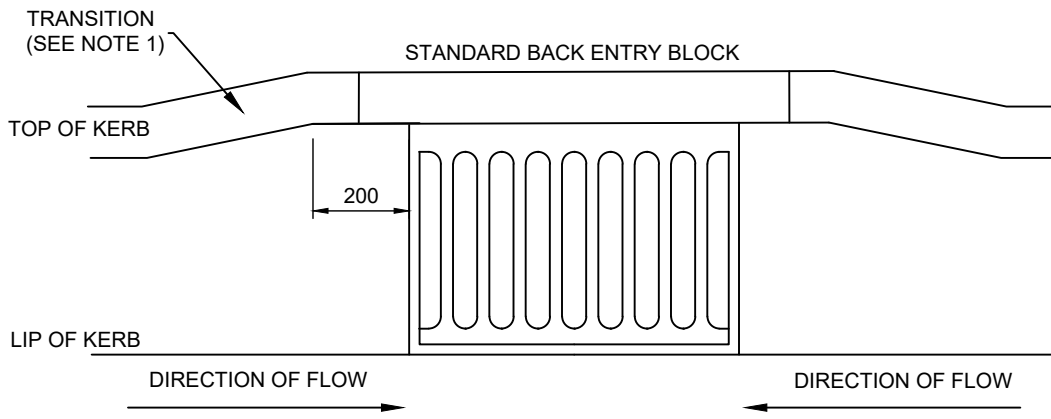

STANDARD ROAD SUMP

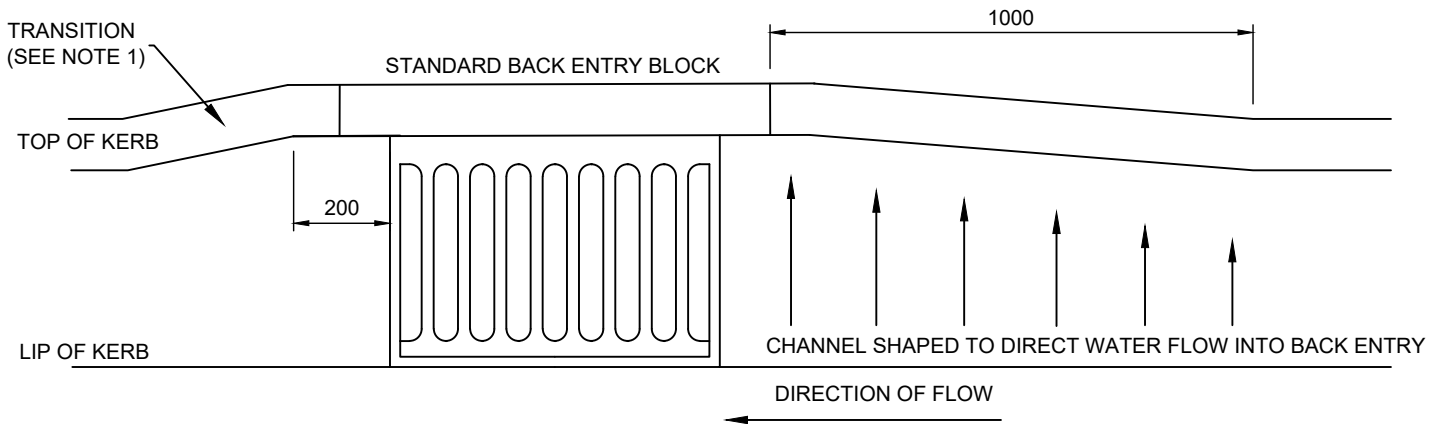

ROAD SUMP IN HILLSIDE CHANNEL

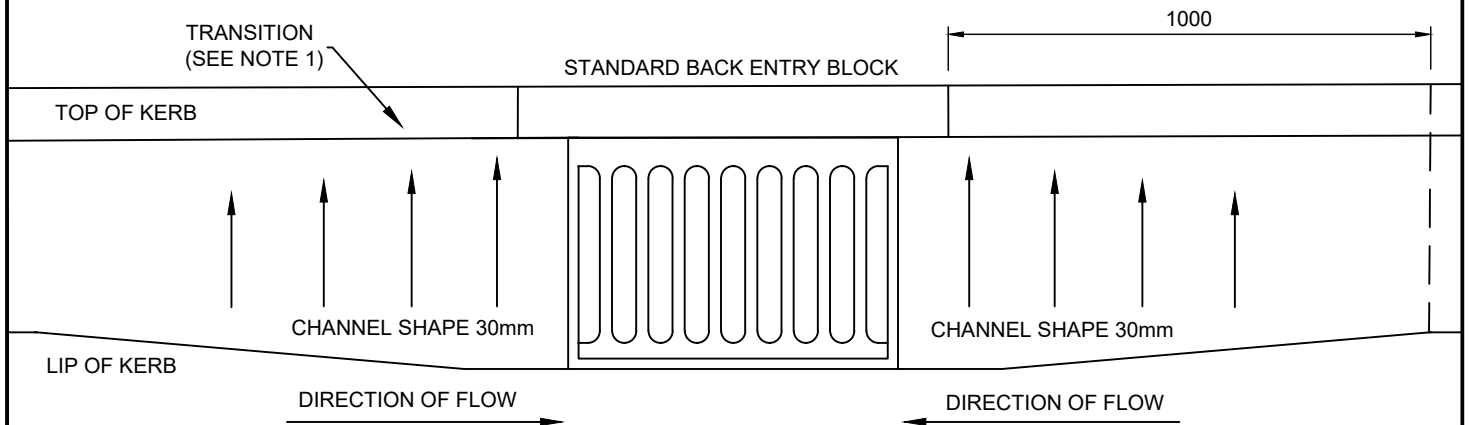

ROAD SUMP DETAIL WHERE NO VERGE

(BACK OF KERB AGAINST FOOTPATH)

NOTE:

1. WHERE GRADIENTS EXCEED 10%, CHANNEL TRANSITION INTO DOUBLE MUDTANK TO BE 800MM AND CHANNEL TO BE FORMED DIRECTLY INTO BACK ENTRY.

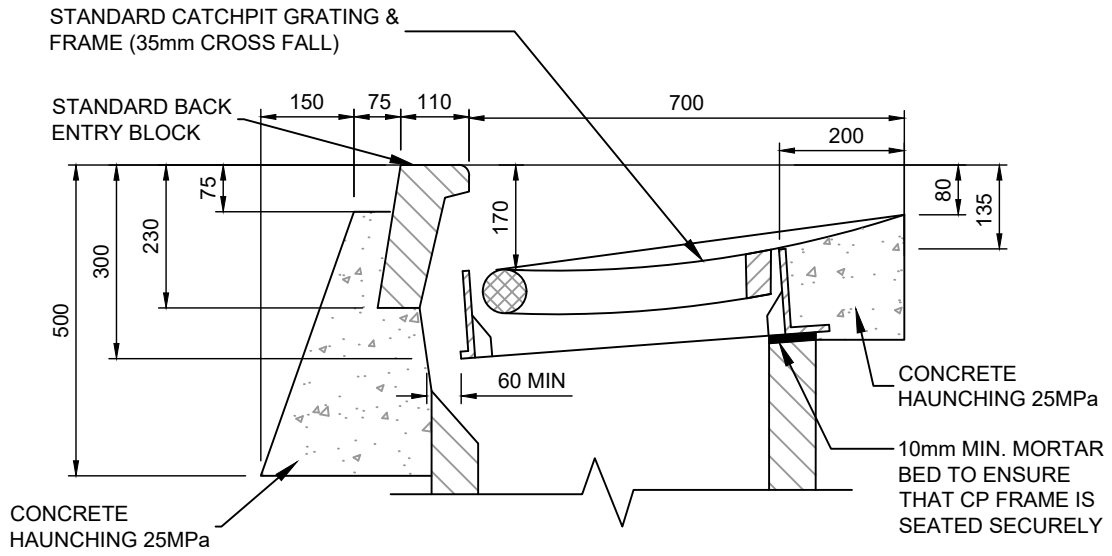

SECTION THROUGH GRATE

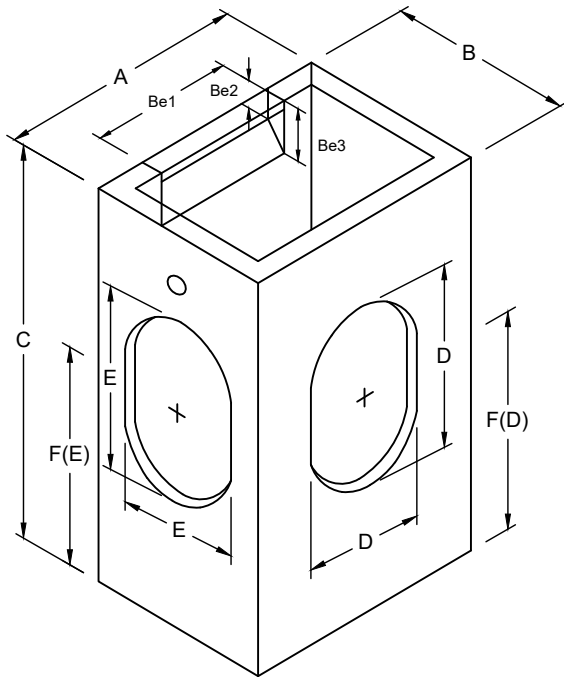

**BACK ENTRY SUMP
ISOMETRIC VIEW**

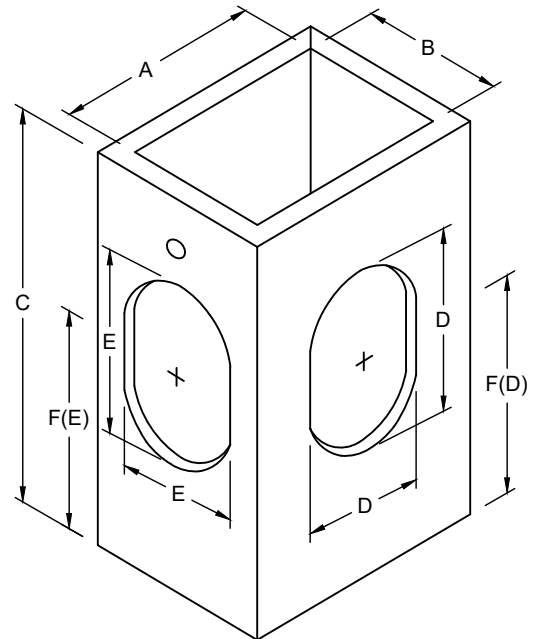
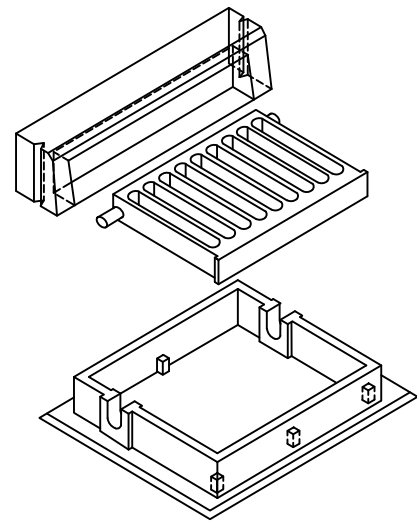

**FLAT TOP SUMP
ISOMETRIC VIEW**

- NOTES:
 1. DIMENSIONS PER MANUFACTURER'S SPECIFICATIONS.
 2. ALL SUMPS SHALL BE A MINIMUM OF 1800 DEPTH.

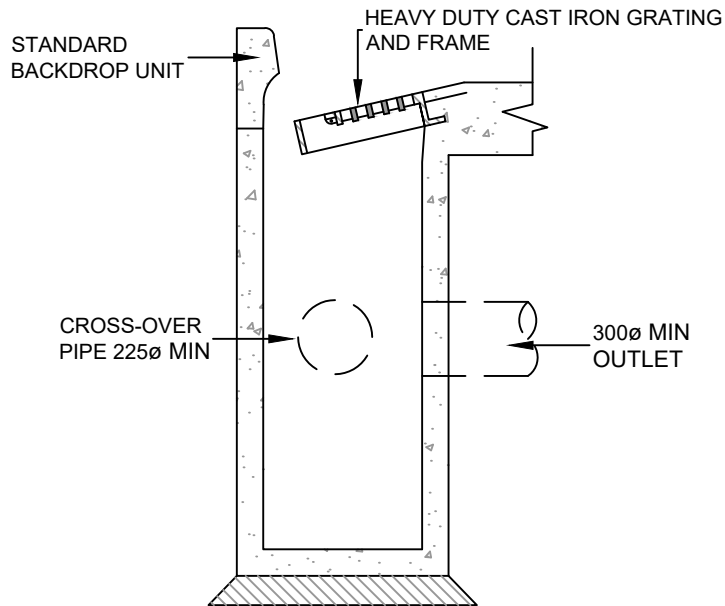
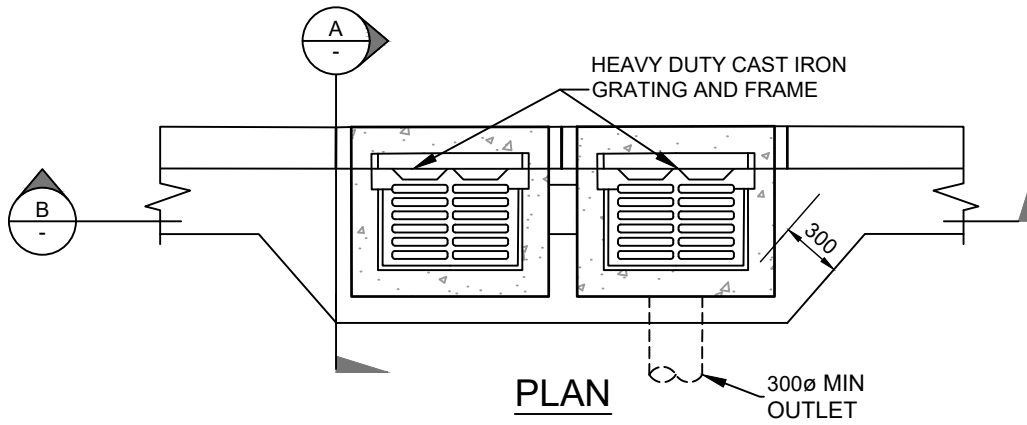

SECTION A

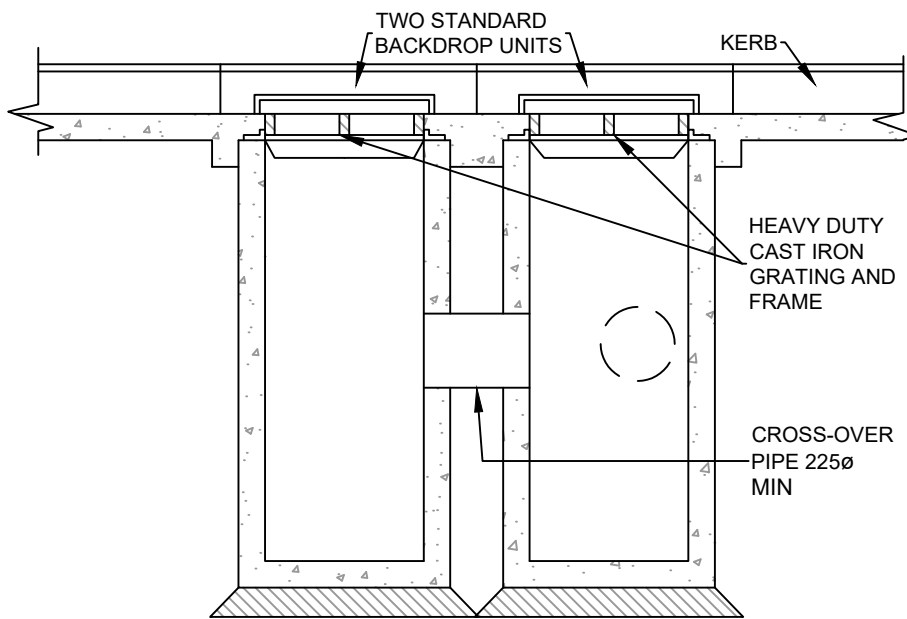

SECTION B

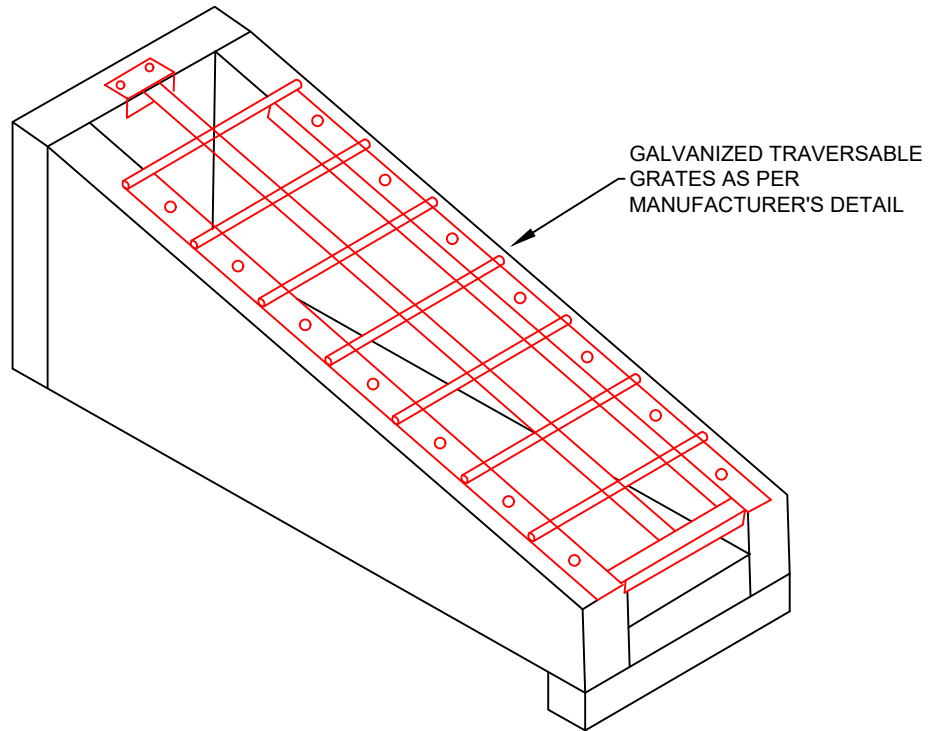

ISOMETRIC VIEW

NOTES:

1. IT IS RECOMMENDED THAT THE GRATES ARE SOURCED FROM THE MANUFACTURER OF THE PRECAST CULVERT HEADWALL TO ENSURE THE GRATE AND HEADWALL ARE COMPATIBLE. OTHERWISE GUIDANCE SHOULD BE SOUGHT FROM THE MANUFACTURER OF THE PRECAST CULVERT HEADWALL ON THE REQUIRED DIMENSIONS FOR ANY GRATES NOT SUPPLIED BY THEM.
2. THE CLEAR WIDTH BETWEEN SIDE WALLS OF PRECAST CULVERT HEADWALLS SHALL NOT EXCEED 600mm WHEN USING THIS GRATE.
3. MATERIAL SPECIFICATIONS FOR THE FOLLOWING ITEMS:
 STEEL GALVANIZED ANGLES - AS/NZS 3679.1:1996 HOT ROLLED BARS AND SECTIONS REINFORCING BARS - AS/NZS 4671:2001
 STEEL REINFORCING MATERIALS GALVANIZING - AS/NZS 4680:2006 HOT DIP GALVANIZING (ZINC) COATINGS ON FABRICATED FERROUS ARTICLES

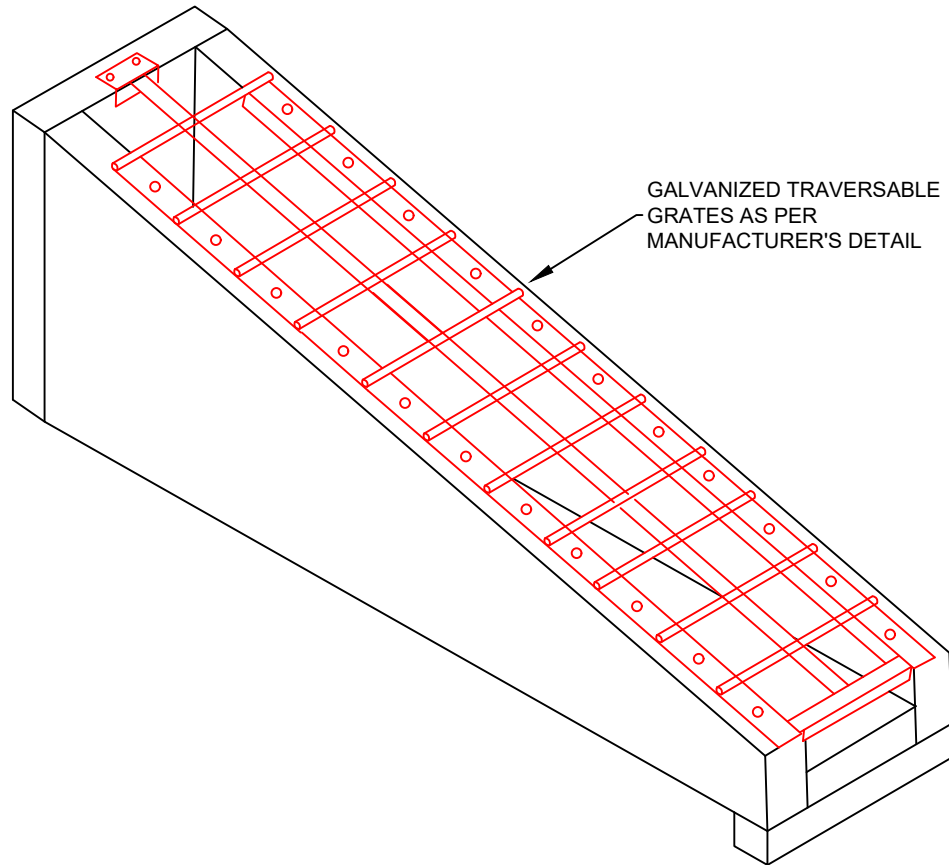

ISOMETRIC VIEW

NOTES:

1. IT IS RECOMMENDED THAT THE GRATES ARE SOURCED FROM THE MANUFACTURER OF THE PRECAST CULVERT HEADWALL TO ENSURE THE GRATE AND HEADWALL ARE COMPATIBLE. OTHERWISE GUIDANCE SHOULD BE SOUGHT FROM THE MANUFACTURER OF THE PRECAST CULVERT HEADWALL ON THE REQUIRED DIMENSIONS FOR ANY GRATES NOT SUPPLIED BY THEM.
2. THE CLEAR WIDTH BETWEEN SIDE WALLS OF PRECAST CULVERT HEADWALLS SHALL NOT EXCEED 600mm WHEN USING THIS GRATE.
3. MATERIAL SPECIFICATIONS FOR THE FOLLOWING ITEMS:
 STEEL GALVANIZING ANGLES - AS/NZS 3679.1:1996 HOT ROLLED BARS AND SECTIONS REINFORCING BARS - AS/NZS 4671:2001 STEEL REINFORCING MATERIALS GALVANIZING - AS/NZS 4680:2006 HOT DIP GALVANIZING (ZINC) COATINGS ON FABRICATED FERROUS ARTICLES.

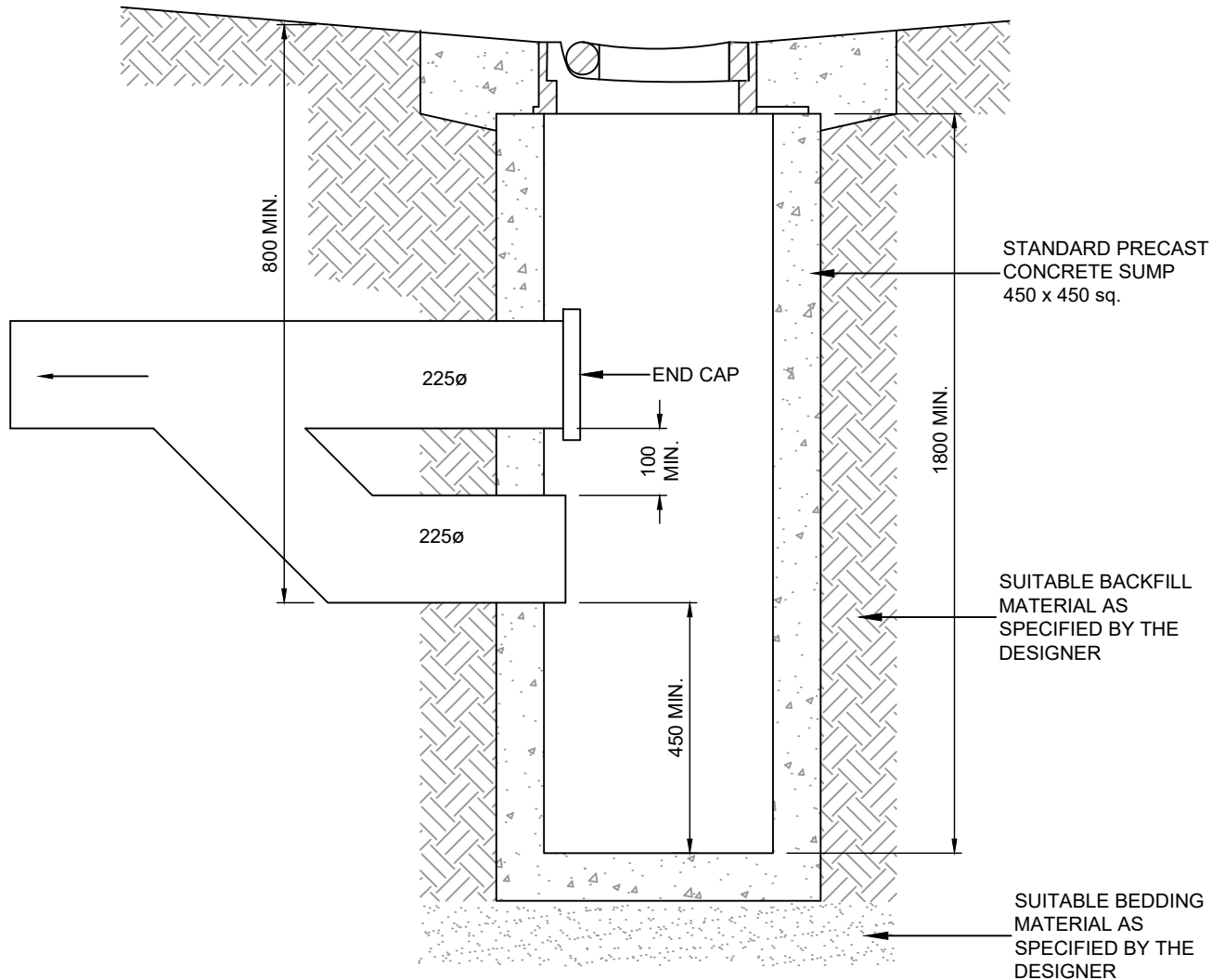
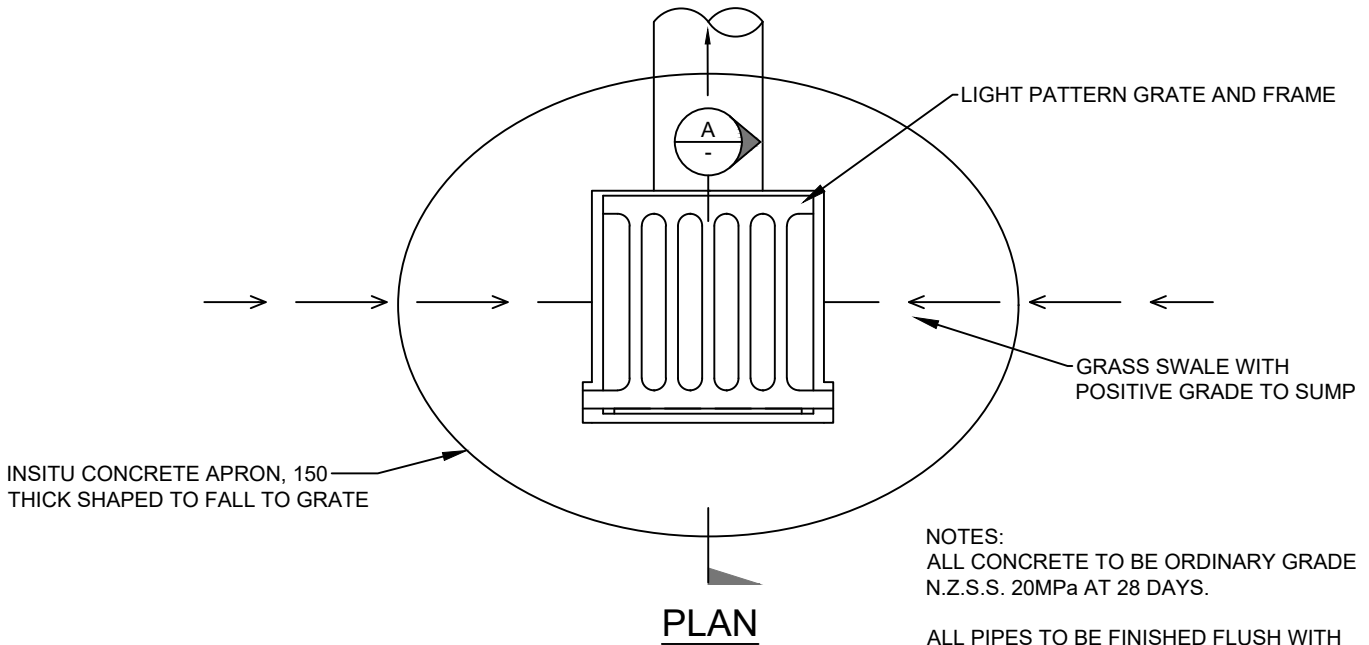

- NOTES:
1. ALL SUMPS SHOULD BE 1800mm DEPTH.
 2. A MINIMUM SEDIMENT STORAGE DEPTH OF 450mm IS TO BE PROVIDED (TO INVERT OF PIPE).

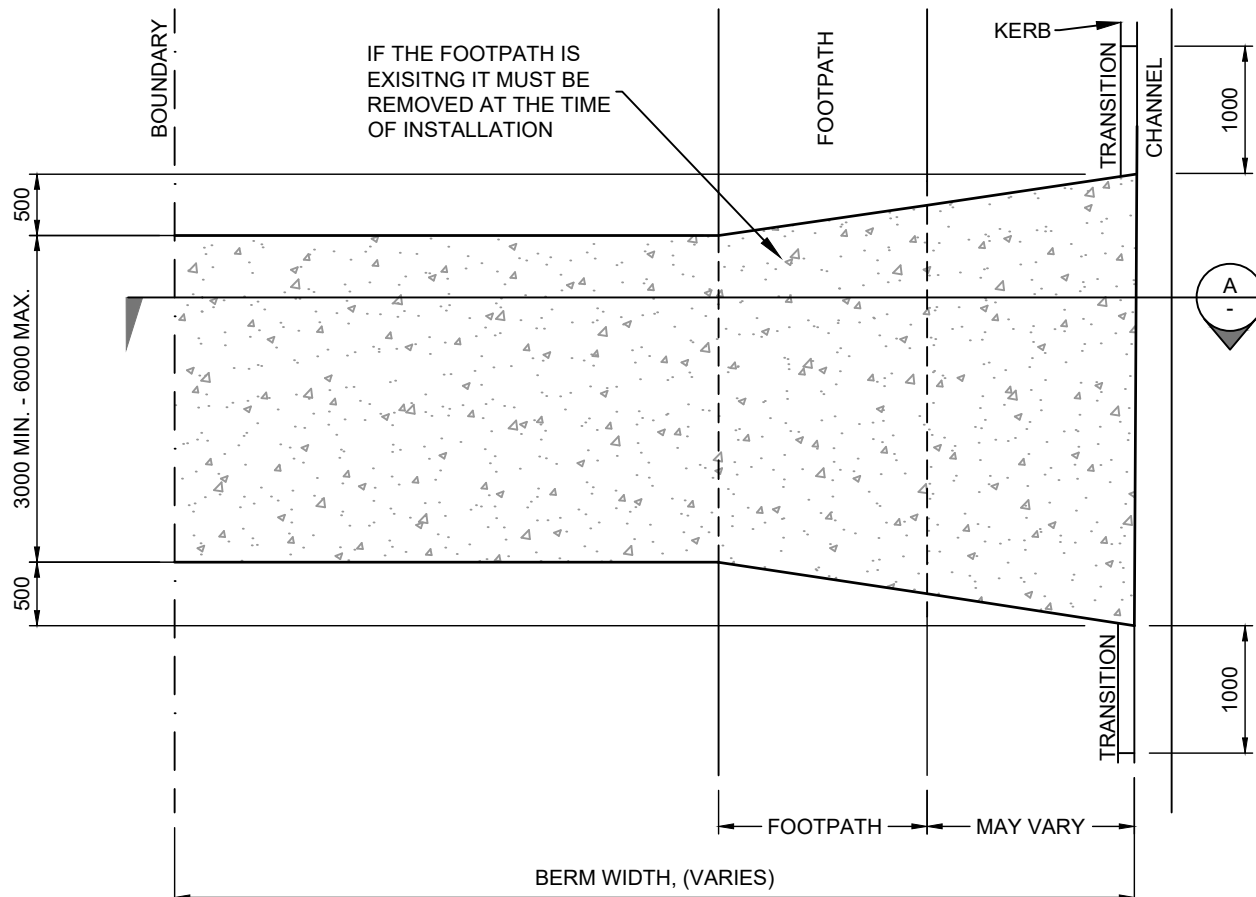

PLAN VIEW

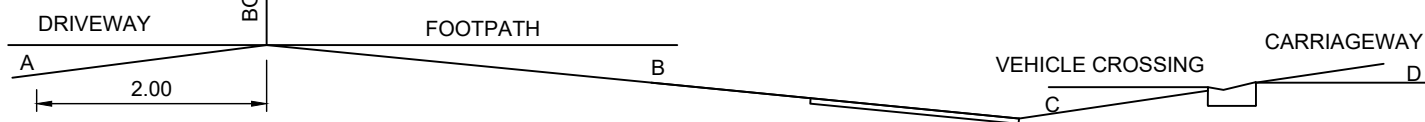

SECTION A: LOW LEVEL FOOTPATH

MAX. CHANGE OF GRADE
IN ACCORDANCE WITH
THE DISTRICT PLAN.

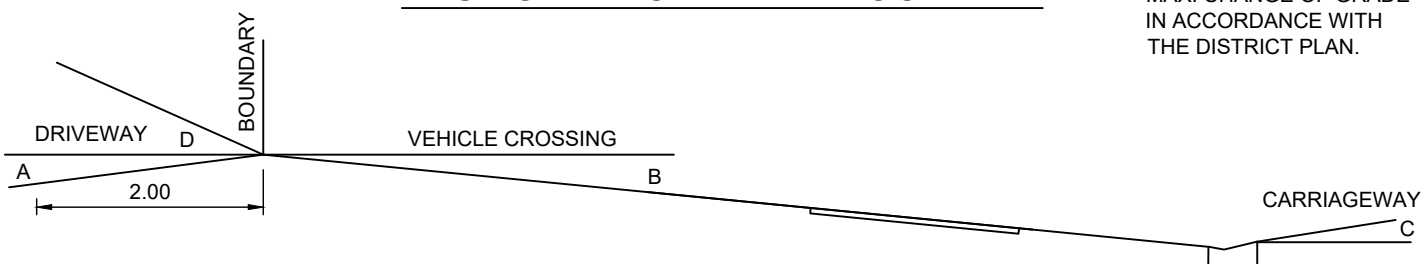

SECTION A: STANDARD FOOTPATH

NOTES:

1. DESIGN OF ALL RESIDENTIAL CROSSINGS TO COMPLY WITH DISTRICT PLAN REQUIREMENTS.
2. CROSSING CONCRETE TO BE 125mm THICK REINFORCED WITH STRUCTURAL MESH, CENTRALLY PLACED.
3. SURFACING TO BE CONCRETE WITH A MINIMUM CRUSHING STRENGTH OF 20MPa AT 28 DAYS, OR 30mm DG7 ASPHALT (NZTA M10 Notes TABLE N3.3), OR 2 COAT SEAL.
4. BASECOURSE TO BE A MINIMUM 150mm COMPACTED DEPTH OF M4 AP40 CRUSHED GRAVEL, OR 150mm M4 AP40 FOR 2 COAT SEAL.
5. SUBGRADE TO BE TRIMMED AND COMPACTED TO ACHIEVE A MINIMUM CBR VALUE = 7.
6. MAXIMUM LONGITUDINAL GRADIENTS SHALL BE IN ACCORDANCE WITH THE DISTRICT PLAN.
7. A, B, C AND D REFER TO THE GRADIENTS EXPRESSED EITHER AS A PERCENTAGE OR IN DEGREES.
8. LOW SLUNG CARS WITH GROUND EFFECT FEATURES MAY NOT MEET THE CRITERIA ASSUMED IN THIS DESIGN GUIDE.

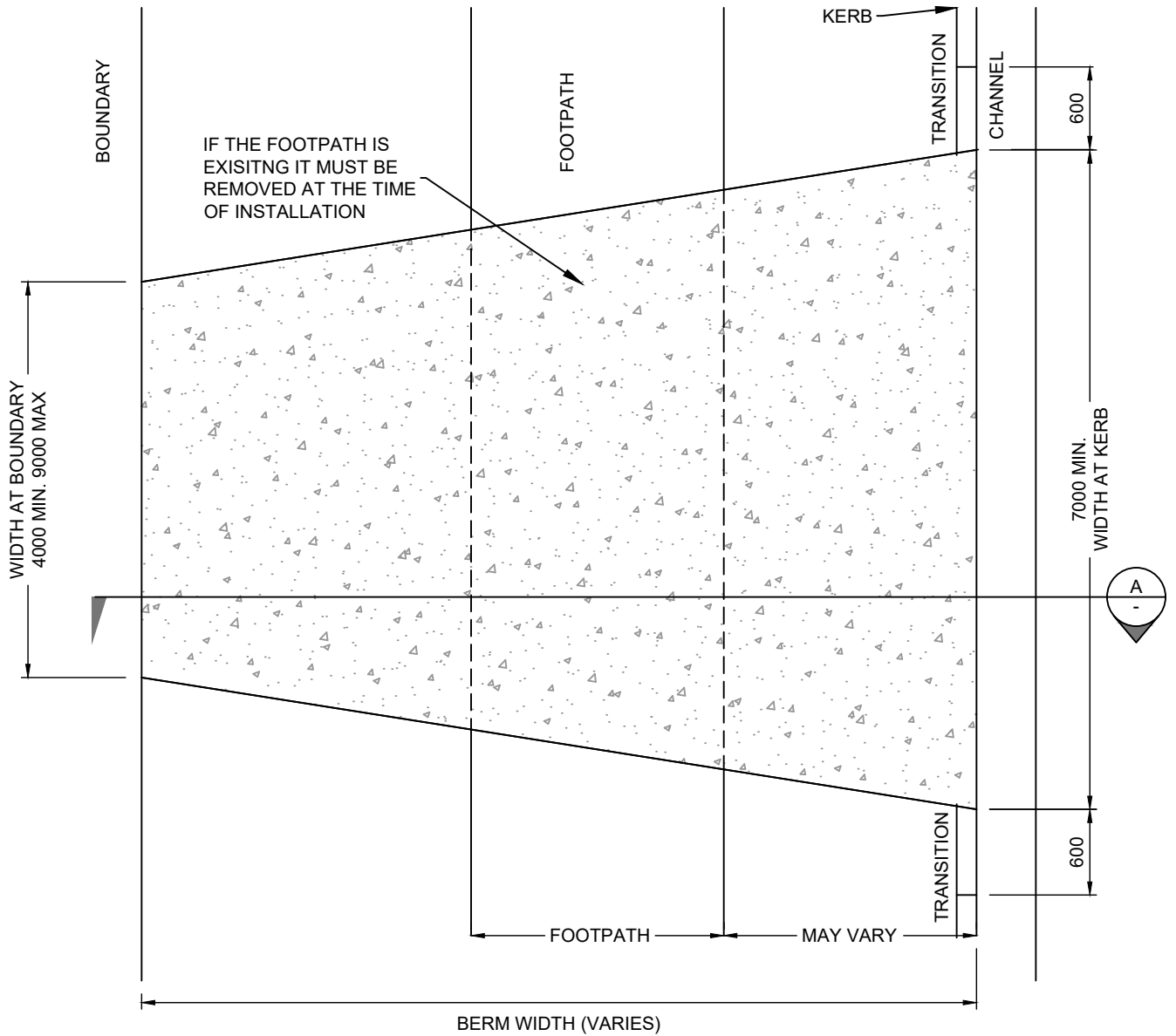

PLAN

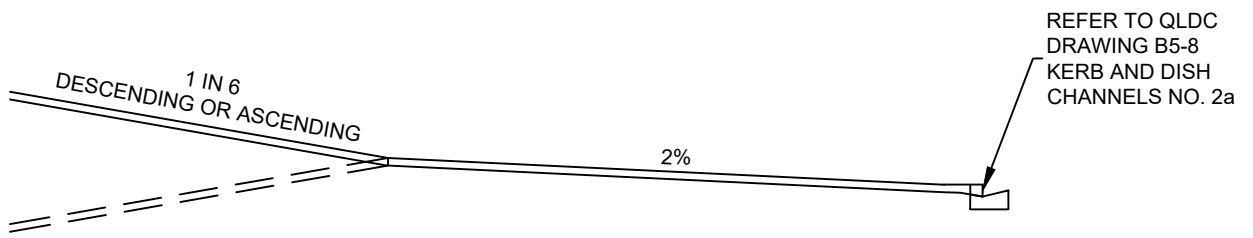

SECTION A

NOTES:

1. THE CONCRETE SHALL BE 150mm THICK AND REINFORCED WITH STRUCTURAL MESH, CENTRALLY PLACED.
2. THE CONCRETE SHALL HAVE A MINIMUM CRUSHING STRENGTH OF 20 MPa AT 28 DAYS AND SHALL COMPLY WITH NZS 3124.
3. CHANNEL CROSSING TO BE HEAVY DUTY, REINFORCED WITH 3 D12 BARS.
4. SUB-GRADE TO BE TRIMMED AND COMPACTED TO ACHIEVE A MIN. CBR VALUE OF > 7.
5. DESIGN OF ALL COMMERCIAL CROSSINGS TO COMPLY WITH THE DISTRICT PLAN.
6. MAXIMUM LONGITUDINAL GRADIENTS SHALL BE IN ACCORDANCE WITH THE DISTRICT PLAN.
7. ONLY CONCRETE IS PERMITTED (ASPHALT NOT PERMITTED).

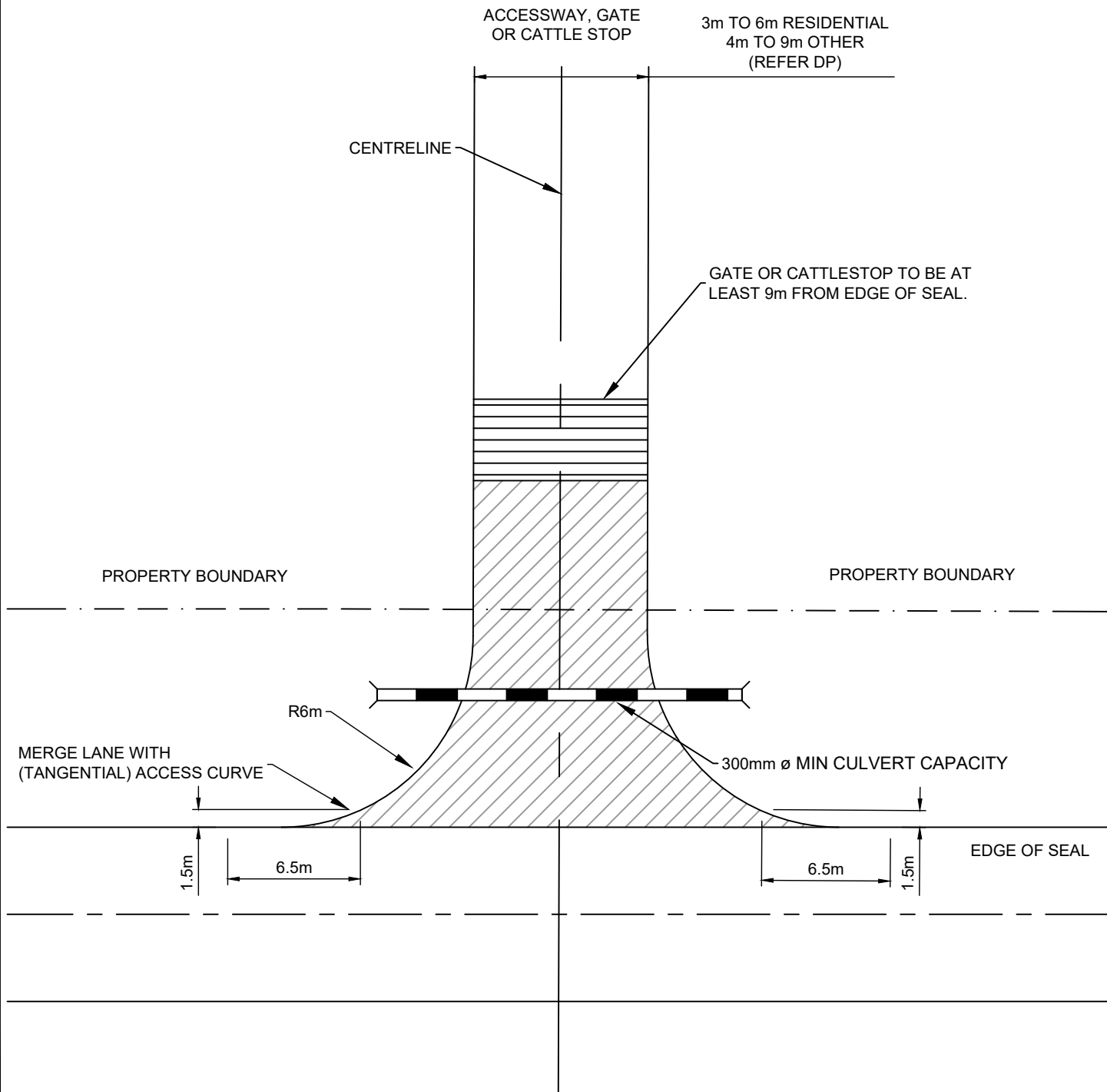

NOTES:

1. CROSSING TO BE MINIMUM 4.5m WIDE AT ENTRANCEWAY & INCORPORATE MIN. 6m RADIUS.
2. PAVEMENT CONSTRUCTION TO BE 150mm COMPACTED DEPTH M/4 AP40 BASECOURSE ON 200mm COMPACTED DEPTH OF AP65 SUBBASE ON COMPACTED SUB-GRADE WITH CBR > 7 (FOR ACCESSWAY INTERNAL TO SITE AS WELL AS LINKING SITE AND LEGAL ROAD).
3. WHERE THE CROSSING INTERCEPTS EXISTING SIDE DRAINAGE, A MIN. 300mm \varnothing CULVERT IS TO BE INSTALLED.
4. IF THE APPLIED SURFACE IS CHIP SEAL A SECOND COAT SEAL IS REQUIRED TO BE PROGRAMMED AND CONSTRUCTED WITHIN 12 MONTHS FROM CONSTRUCTION OF THE FIRST COAT OR IN THE NEXT SUMMER SEASON, WHICHEVER COMES FIRST.
5. CULVERT TO BE FINISHED WITH CONCRETE HEADWALLS AS PER DRAWING B5-24: NON-PRECAST HEADWALL DETAIL OR DRAWING B5-16: TRAVERSABLE GRATES FOR PRECAST HEADWALLS 250mm TO 450mm CULVERTS.
6. MINIMUM DEPTH OF 450mm TO TOP OF CULVERT IS REQUIRED OR CONCRETE CAPPED/ENCASED IF THE ROAD DEPTH CANNOT BE ACHIEVED OR AS AGREED WITH THE T.A.

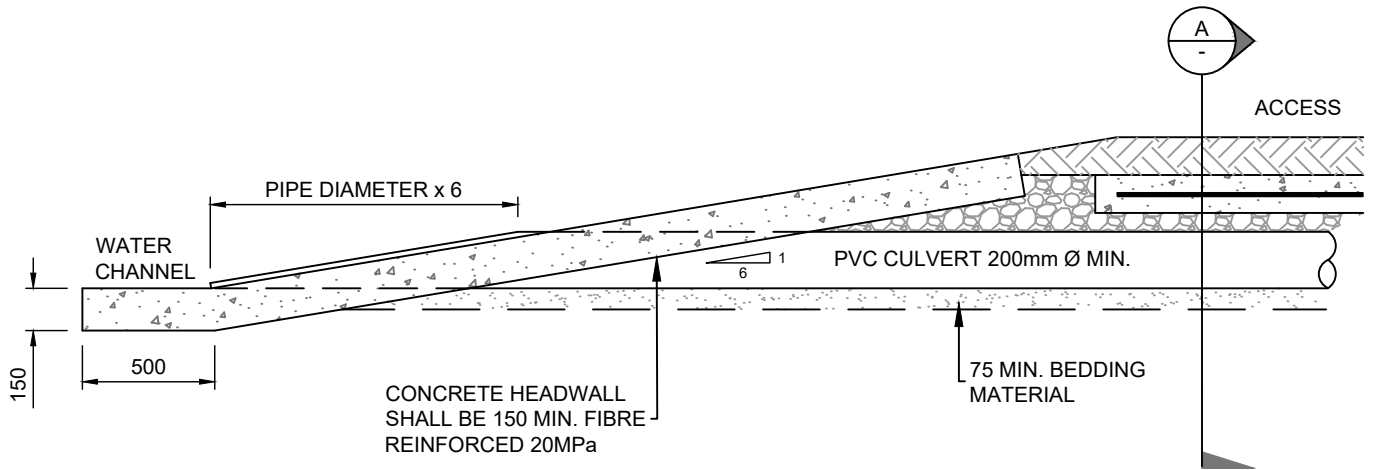

LONGITUDINAL ELEVATION: HEADWALL

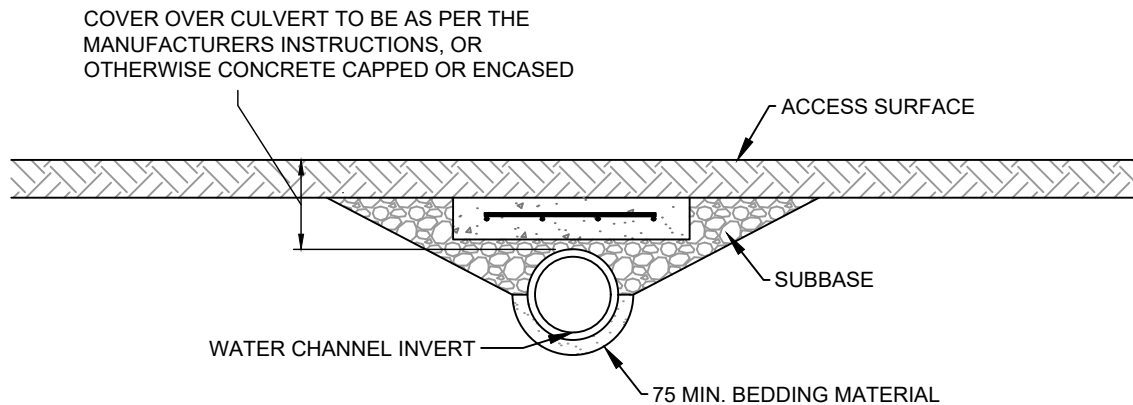

SECTION A: ACCESS PIPE BEDDING

NOTES:

1. WHERE THE ACCESS INTERCEPTS EXISTING SIDE DRAINAGE / WATER TABLE, A 200mm MIN. DIAMETER (OR MIN. DIAMETER OF UPSTREAM CULVERT, WHICHEVER IS THE GREATER) CULVERT IS TO BE INSTALLED.
2. PIPE TO SN8 PVC OR CONCRETE WITH APPROPRIATE BEDDING.
3. COVER OVER CULVERT TO BE AS PER THE MANUFACTURERS INSTRUCTIONS, OR OTHERWISE CONCRETE CAPPED OR ENCASED IF AN APPROPRIATE DEPTH CANNOT BE ACHIEVED.
4. CULVERT ENDS TO BE MITRED TO A GRADIENT OF 1V:6H.
5. CONSTRUCT CONCRETE HEADWALL AND APRON AROUND PIPE ENDS AND CHANNEL INVERT.

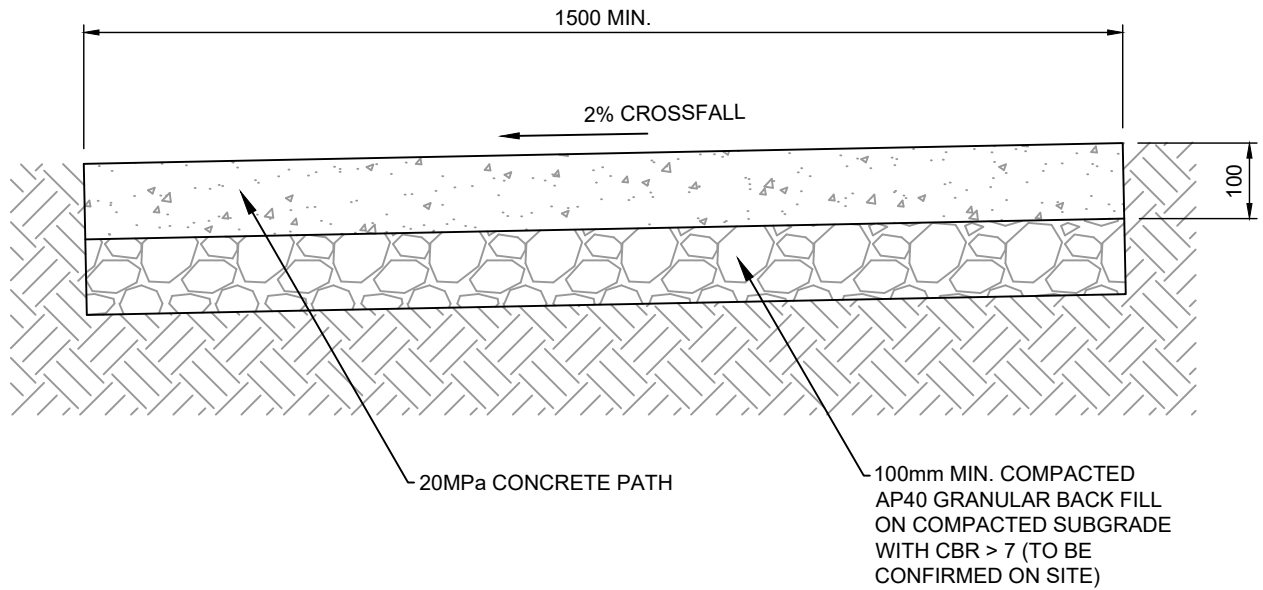

CONCRETE FOOTPATH

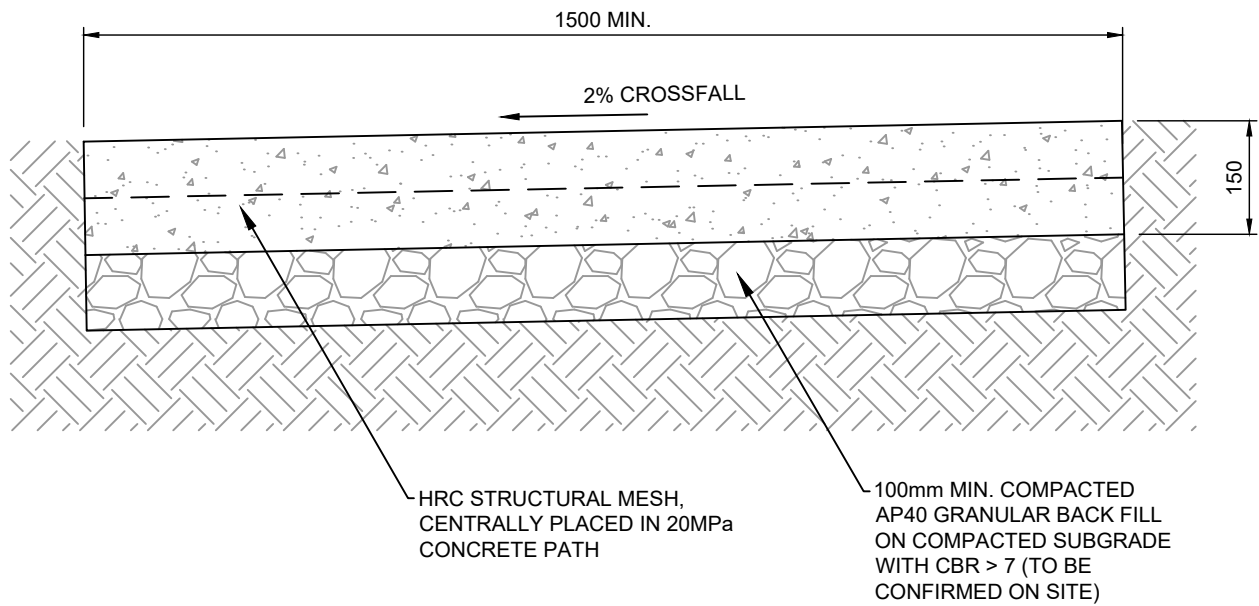

HEAVY DUTY CONCRETE FOOTPATH

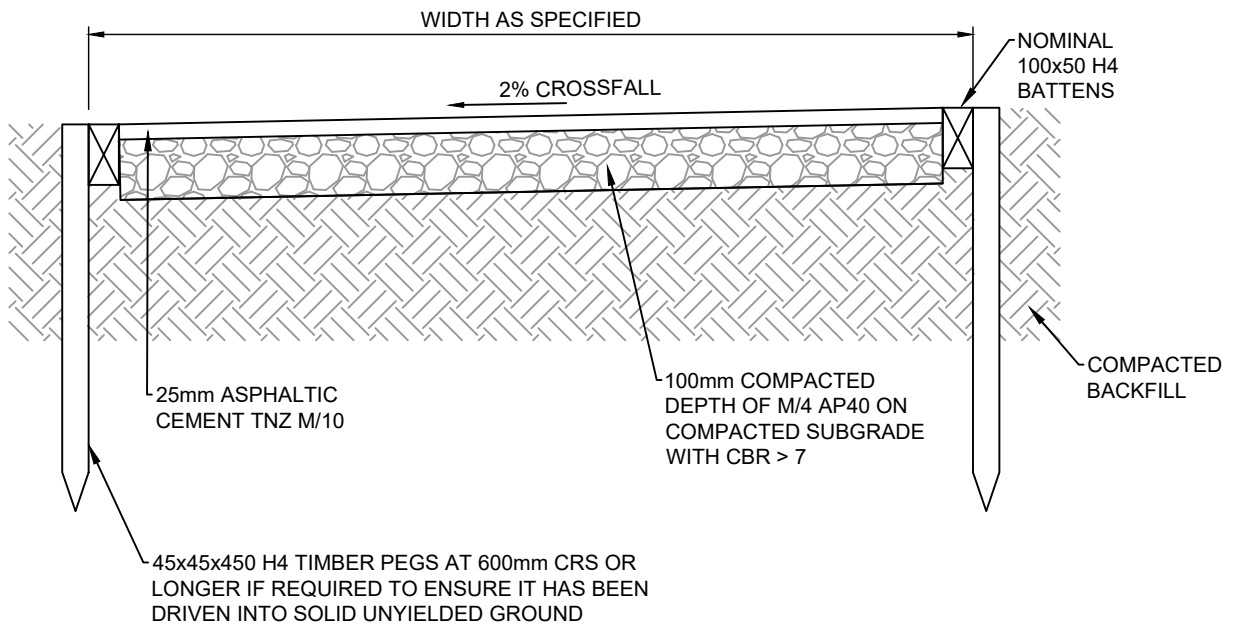

ASPHALT FOOTPATH

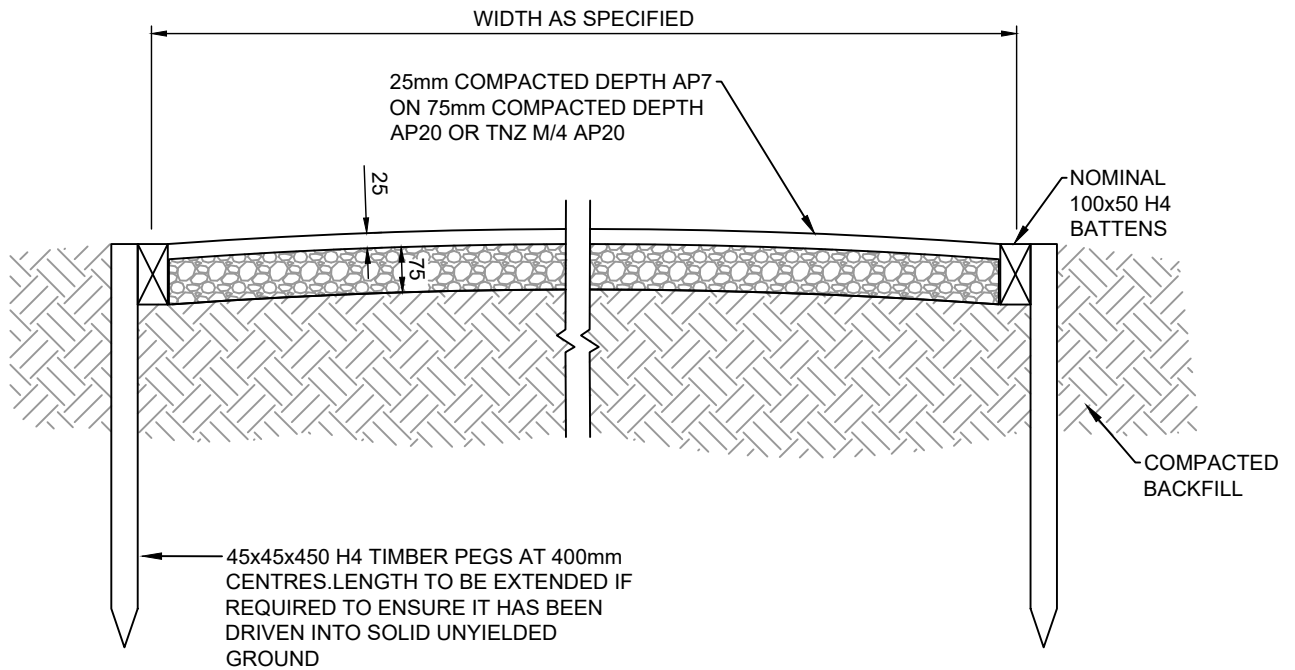

GRITTED FOOTPATH

NOTES:

1. RE. MIN. CBR OF 7 REQUIRED AND SUBBASE OF 75mm.
2. CROSSFALLS TO BE NOMINALLY 3% (CROWNED OR CONTINUOUS CROSSFALLS AS SPECIFIED).
3. SUBGRADE & METALCOURSE TO BE TREATED WITH APPROVED SOIL STERILANT.
4. PEGS CAN BE CUT OFF AT AN ANGLE, FLUSH WITH BOXING ON SIDE AND MINIMUM 5mm DOWN ON THE OTHER.
5. TRACKS AND TRAILS TO BE DESIGNED AND BUILT AS PER THE QLDC TRACKS AND TRAILS DESIGN GUIDE.

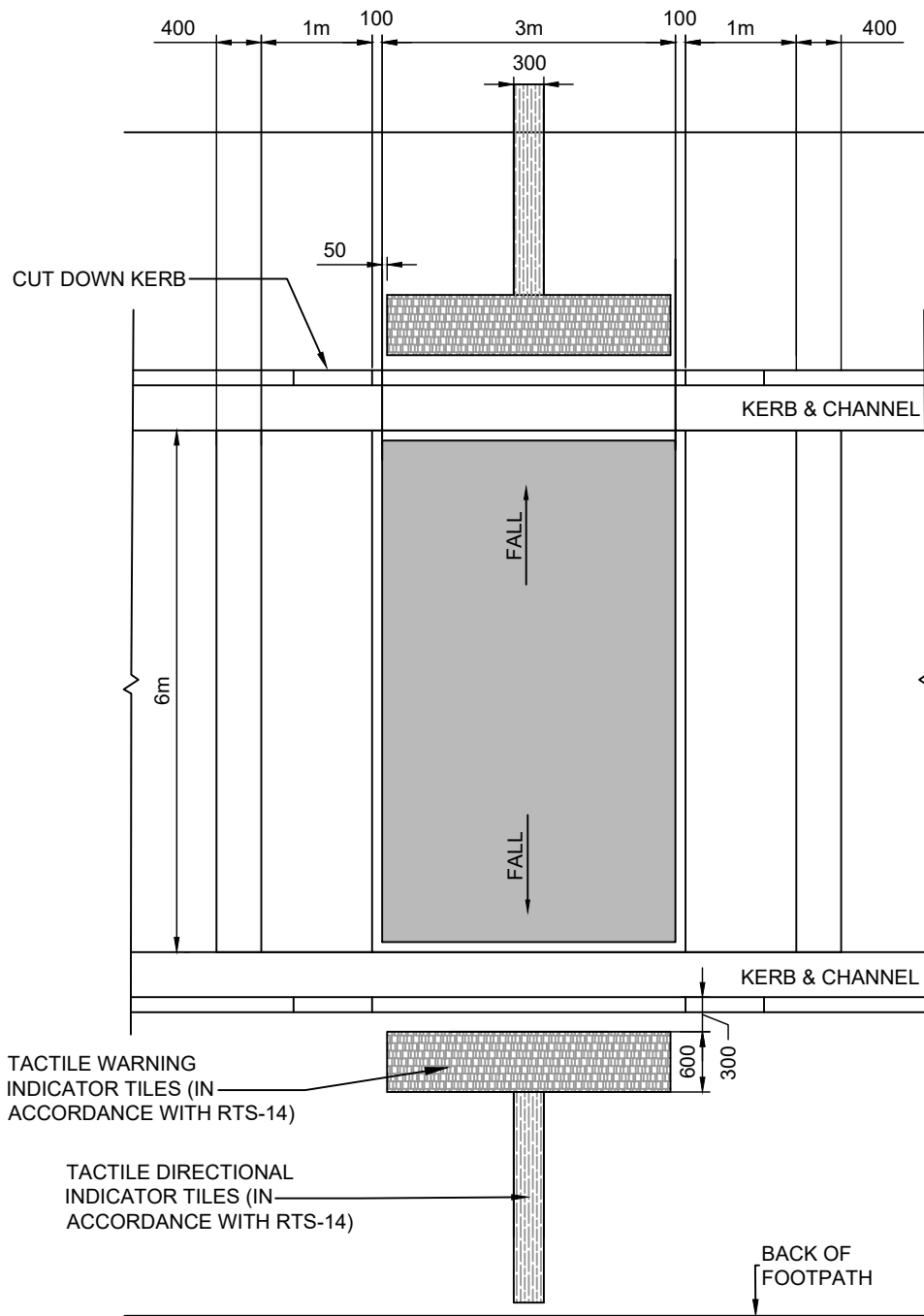

PLAN

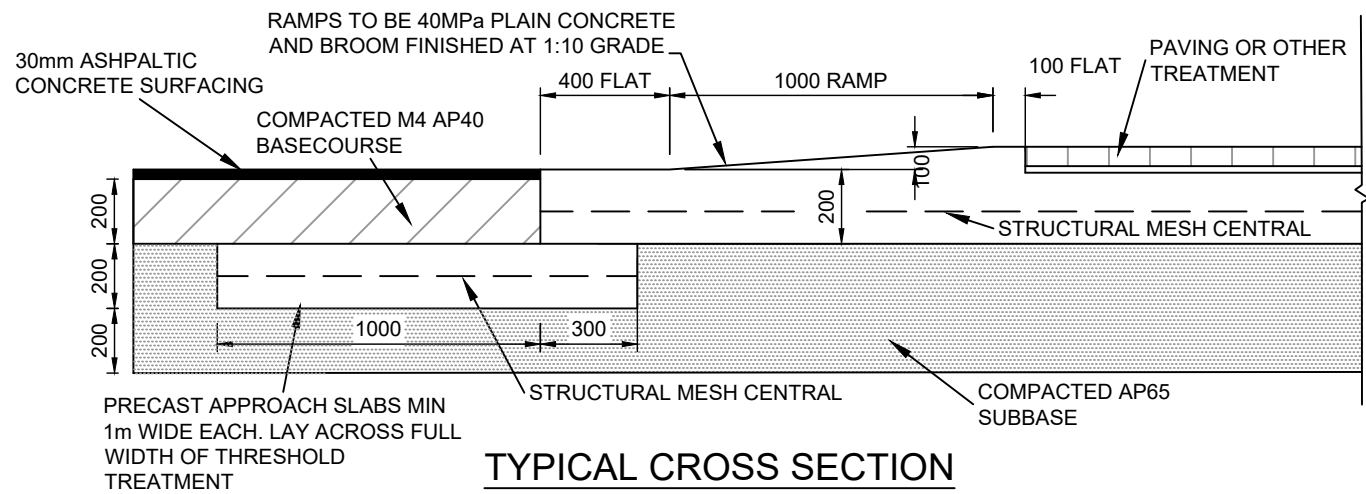

TYPICAL CROSS SECTION

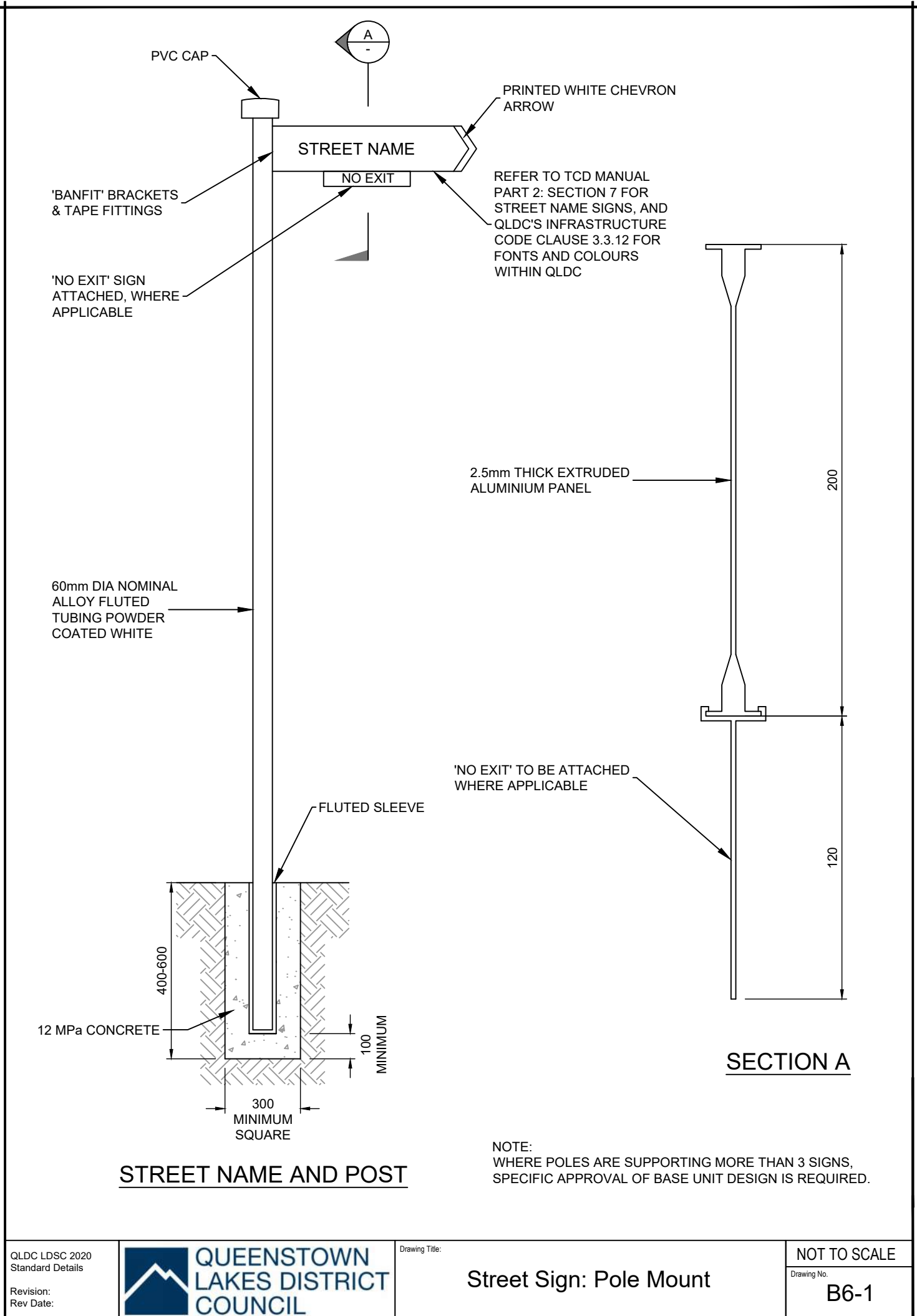

STREET NAME AND POST

SECTION A

NOTE:
WHERE POLES ARE SUPPORTING MORE THAN 3 SIGNS,
SPECIFIC APPROVAL OF BASE UNIT DESIGN IS REQUIRED.

MATERIAL		ZONE
ROAD SURFACE	NON ROAD SURFACES	
ROAD SURFACE LAYER	TO MATCH EXISTING	SURFACE COURSE
TO MATCH EXISTING ROAD BASE OR TO TERRITORIAL AUTHORITY REQUIREMENTS	TRENCH FILL MATERIALS TO BE SIMILAR WITH SNZ HB 2002 APPENDIX L OR TO TERRITORIAL AUTHORITY REQUIREMENTS	ROAD BASE
TRENCH FILL MATERIALS TO BE SIMILAR WITH SNZ HB 2002 APPENDIX L OR TO TERRITORIAL AUTHORITY REQUIREMENTS	OR	TRENCH FILL (AS SPECIFIED IN DESIGN DRAWINGS)
OR	INORGANIC FILL MATERIAL WITH 75 MAXIMUM STONE SIZE	
EMBEDMENT MATERIAL IN ACCORDANCE WITH DESIGN DRAWINGS AND TERRITORIAL AUTHORITY (SEE NOTE 4)		OVERLAY
BEDDING MAY BE OMITTED IF TRENCH BASE IS GRANULAR SAND OR GRAVEL OF SUITABLE GRADING		SIDE SUPPORT
		BEDDING
		OVER-EXCAVATION
		EMBEDMENT

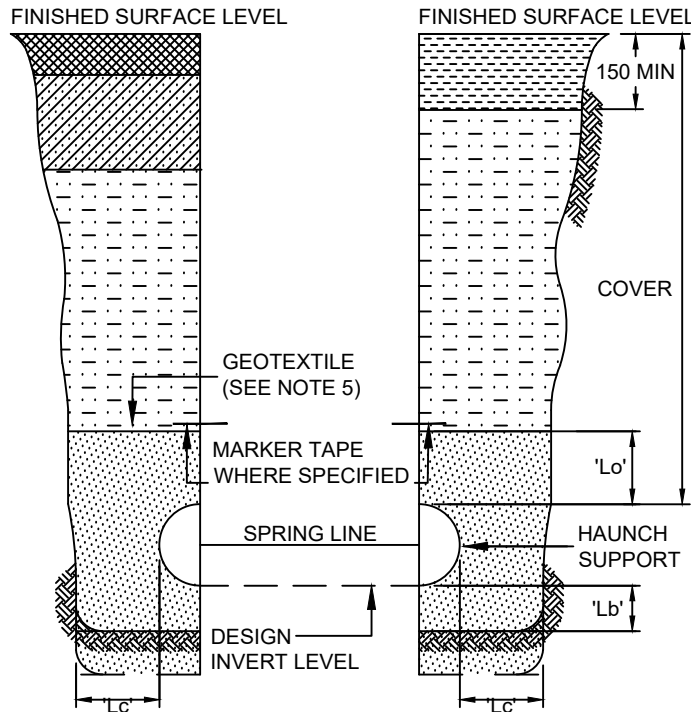

ZONE	MATERIAL
TOPSOIL OR PAVEMENT	ORIGINAL OR IMPORTED MATERIAL TO MATCH EXISTING
TRENCH FILL (AS SPECIFIED IN DESIGN DRAWINGS)	INORGANIC FILL MATERIAL WITH 75 MAXIMUM STONE SIZE
OVERLAY	EMBEDMENT MATERIAL IN ACCORDANCE WITH DESIGN DRAWINGS AND TERRITORIAL AUTHORITY (SEE NOTE 4)
SIDE SUPPORT	
BEDDING	BEDDING MAY BE OMITTED IF TRENCH BASE IS GRANULAR SAND OR GRAVEL OF SUITABLE GRADING
OVER-EXCAVATION	

VEHICULAR LOADING

'Lo' - 100 mm MIN. NON TRAFFICABLE
 'Lb' - 300 mm MIN. TRAFFICABLE
 - REFER TO CM - 002

NOTE:

- ALL DIMENSIONS IN MILLIMETRES.
- SPECIFY SPECIAL BEDDING TO SUIT THE CONDITIONS IF THE TRENCH FLOOR HAS:
 - IRREGULAR OUTCROPS OF ROCK OR
 - BEEN DISTURBED BY UNCONTROLLED GROUND WATER.
- COMPACT AND EVENLY GRADE FINISHED TRENCH FLOOR.
- EMBEDMENT, TRENCH FILL AND COMPACTION TO MEET THE REQUIREMENT OF DESIGN DRAWINGS OR SPECIFICATIONS.
- USE GEOTEXTILE FILTER FABRIC WHERE SPECIFIED.
- SIDES OF EXCAVATION TO BE KEPT VERTICAL TO AT LEAST 150 ABOVE THE PIPE.

SPRING LINE TRENCH CLEARANCE

NOMINAL DIAMETER DN	MINIMUM CLEARANCE 'Lc'
≤150	100
>150 - ≤300	150
>300 - ≤450	200
>450 - ≤900	300
>900 - ≤1500	350

TRENCH WIDTH TO BE SUFFICIENT TO SAFELY LAY PIPE AND COMPACT THE SIDE SUPPORT ZONE

NO VEHICULAR LOADING

INCLUDES LOCATIONS WHERE OCCASIONAL VEHICLE LOADING OCCURS SUCH AS RESERVES AND FOOTWAYS



PIPE JOINT BEDDING POCKETS

FOR JOINT PROJECTIONS (SOCKETS, FLANGES, AND SO ON)

<p>ORIGINAL SOURCE DRAWINGS: WATER SERVICES ASSOCIATION OF AUSTRALIA</p>	NZS 4404:2010 LAND DEVELOPMENT AND SUBDIVISION INFRASTRUCTURE	NOT TO SCALE
	<h2>EMBEDMENT & TRENCHFILL TYPICAL ARRANGEMENT</h2>	
		CM - 001
		B7-1

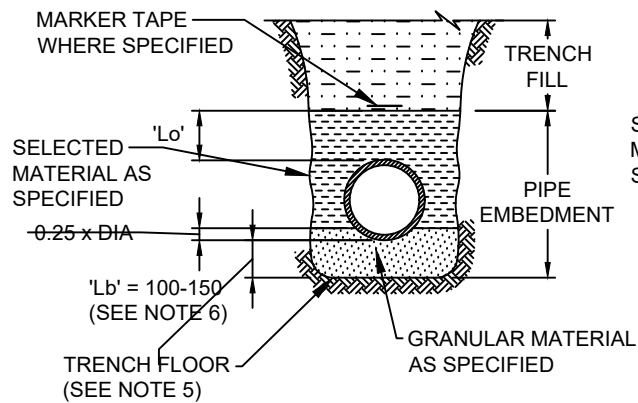

TYPE 1 SUPPORT

(SEE NOTE 9)

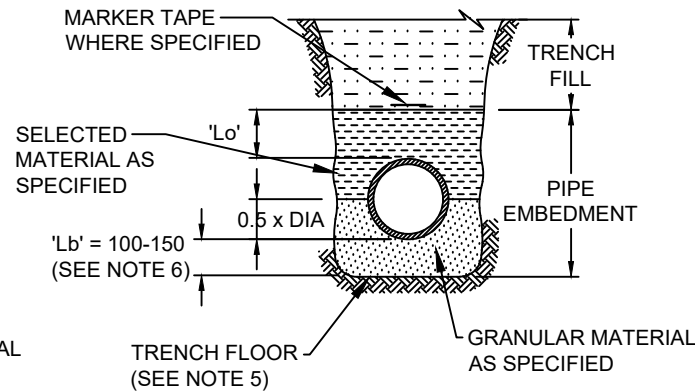

TYPE 2 SUPPORT

FOR RIGID PIPES ONLY (SEE NOTE 3)
(SEE NOTE 9)

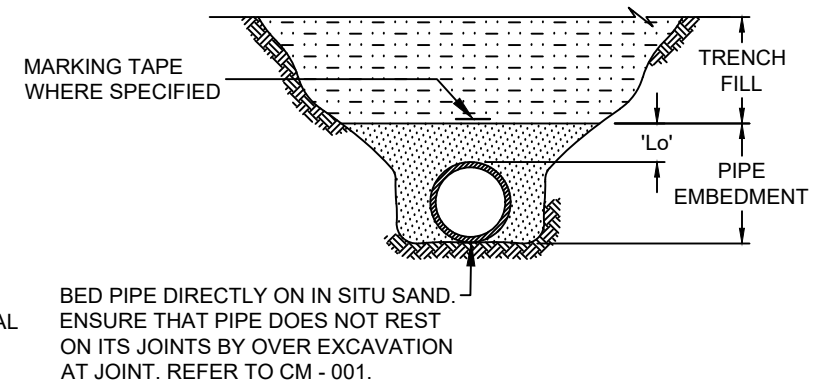

TRENCH IN SAND STRATA

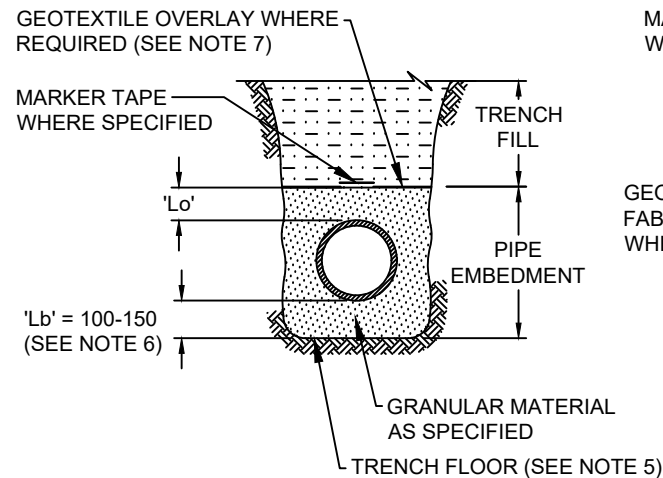

TYPE 3 SUPPORT

FOR FLEXIBLE AND RIGID PIPES (SEE NOTE 3)

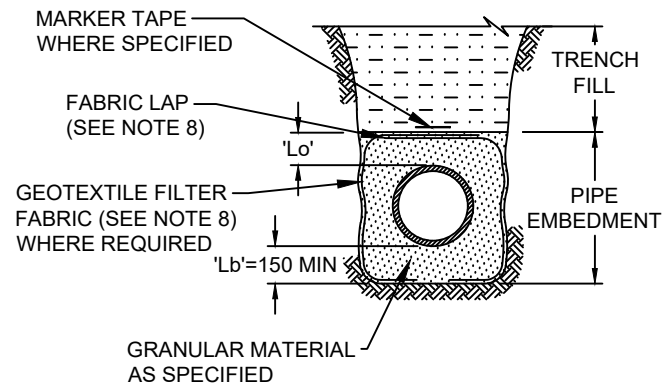

TYPE 4 SUPPORT

WITH GEOTEXTILE FOR FLEXIBLE AND RIGID PIPES (SEE NOTE 3)

NOTES:

- ALL DIMENSIONS IN MILLIMETRES.
- THIS DRAWING TO BE READ IN CONJUNCTION WITH CM - 001.
- PIPE CLASSIFICATION:
 - RIGID PIPES: VC, RC, STEEL AND DI
 - FLEXIBLE PIPES: PVC, GRP, AND PE.
- PLACEMENT OF EMBEDMENT, TRENCHFILL, & COMPACTION TO MEET THE REQUIREMENTS OF DRAWINGS AND SPECIFICATIONS.
- EXCAVATE OR COMPACT TRENCH FLOOR TO PROVIDE A FLAT FIRM BASE TO SUPPORT BEDDING MATERIAL AND MINIMISE PIPELINE SETTLEMENT. WHEN EXCAVATED, REPLACE WITH GRANULAR MATERIAL AS SPECIFIED FOR BEDDING OR ADOPT TYPE 1, 2, 3, OR 4 SUPPORT AS REQUIRED.
- ENSURE BEDDING IS DEEP ENOUGH THAT PIPE JOINT PROJECTIONS (SOCKETS, FLANGES) DO NOT TOUCH TRENCH FLOOR -SEE CM-001.
- TYPE 4 SUPPORT TO BE USED WHERE MIGRATORY NATIVE SOILS (SANDS & CLAYS) ARE ENCOUNTERED ADJACENT TO THE EMBEDMENT ZONE AND SINGLE SIZE AGGREGATE IS USED.
- GEOTEXTILE OVERLAY IS REQUIRED FOR COARSE AGGREGATE EMBEDMENT > 5mm. LAY GEOTEXTILE FILTER FABRIC AGAINST TRENCH FLOOR AND WALLS SUCH THAT IT FULLY ENCASES THE EMBEDMENT.
 - PRESS FILTER FABRIC INTO THE VOIDS BEFORE INSTALLING EMBEDMENT TO PREVENT FABRIC TEARING.
 - PROVIDE A MINIMUM OF 250 OVERLAP AT ALL FILTER FABRIC JOINTS.
- IN SOME AREAS LOCAL PRACTICE MAY ALLOW USE OF SELECTED EXCAVATED MATERIAL AS PIPE EMBEDMENT.
- IN UNSUITABLE GROUND CONDITIONS SPECIFIC DESIGN IS REQUIRED. SEE WSA 03 & WSA 04 DRAWINGS FOR GUIDANCE.
- CONCRETE PIPES SHOULD BE BASED ON FIGURES 11 - 13 IN AS/NZS 3725.

EMBEDMENT TYPES TO BE SPECIFIED IN DESIGN DRAWINGS

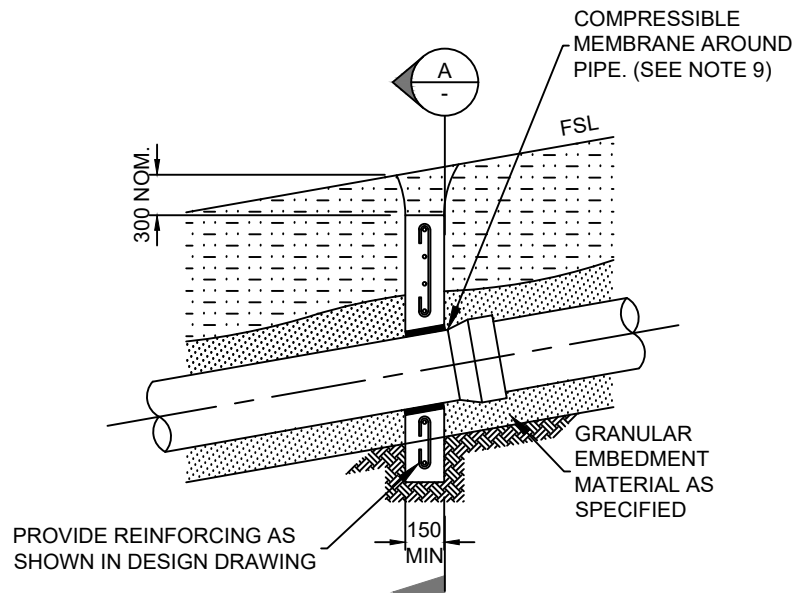

CONCRETE BULKHEAD DETAIL

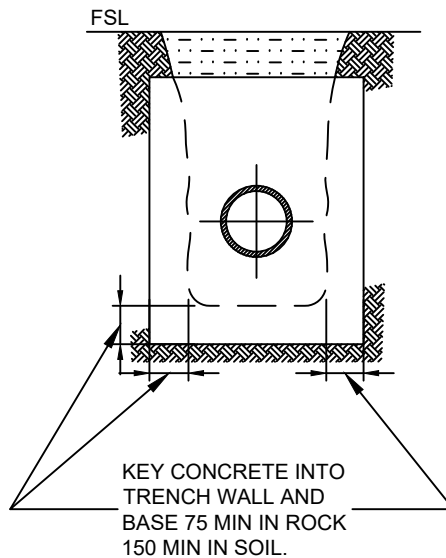

SECTION A

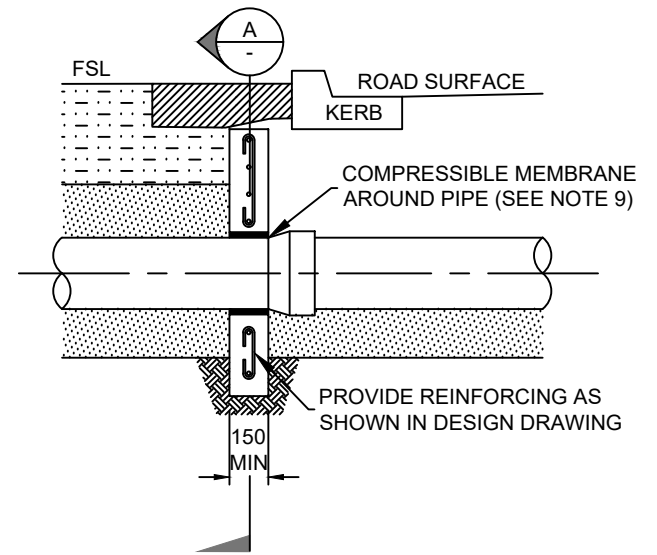

TYPICAL ROAD CROSSING BULKHEAD

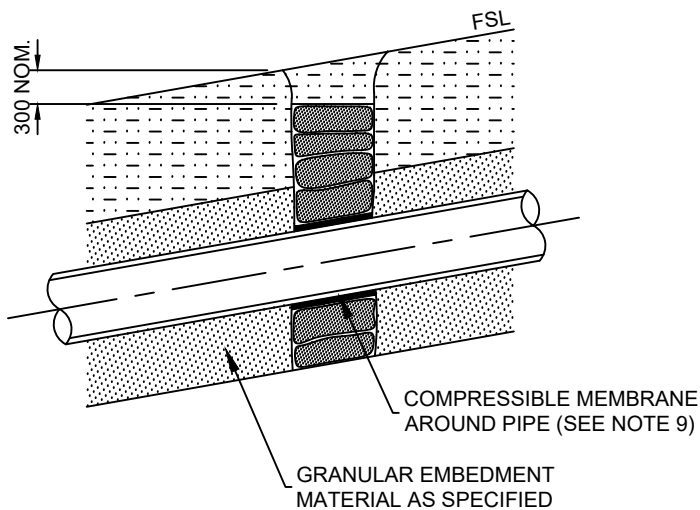

TRENCH STOP DETAIL

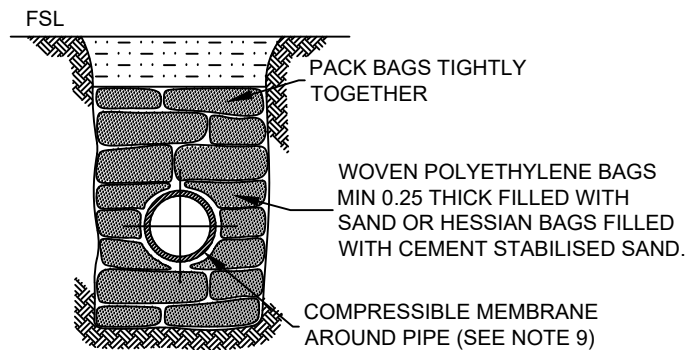

SECTION B

NOTES:

1. ALL DIMENSIONS IN MILLIMETRES.
2. CONSTRUCT CONCRETE BULKHEADS AND TRENCH STOPS AT LOCATIONS SPECIFIED IN DESIGN DRAWINGS.
3. CONSTRUCT BULKHEAD ADJACENT TO KERB AND GUTTER SHOULDER OF SEALED ROADS.
4. BULKHEAD AT A RETAINING WALL TO BE UNDER THE WALL.
5. KEY CONCRETE BULKHEADS INTO SIDES AND BOTTOM OF TRENCH AGAINST A BEARING SURFACE OF UNDISTURBED SOIL.
6. CONCRETE TO BE 17.5 MPA.
7. DO NOT DEFORM PIPES DURING PLACEMENT OF CONCRETE OR BAGS.
8. SEAL BAGS TO PREVENT LEAKAGE OF CONTAINED MATERIAL.
9. COMPRESSION MEMBRANE AROUND PIPE TO BE 10 THICK POLYSTYRENE FOR BULKHEADS ADJACENT TO KERBS AND 3 THICK RUBBER FOR BULKHEADS AND TRENCHSTOPS ON SLOPES.
10. FOR SLOPES >35% REFER TO TERRITORIAL AUTHORITY FOR REQUIREMENTS.

 STANDARDS NEW ZEALAND <small>PAEREVA AOTEAROA</small> <small>ORIGINAL SOURCE DRAWINGS: WATER SERVICES ASSOCIATION OF AUSTRALIA</small>	NZS 4404:2010 LAND DEVELOPMENT AND SUBDIVISION INFRASTRUCTURE	NOT TO SCALE	
	BULKHEADS & TRENCH STOP STANDARD DETAILS		CM - 003
		B7-3	

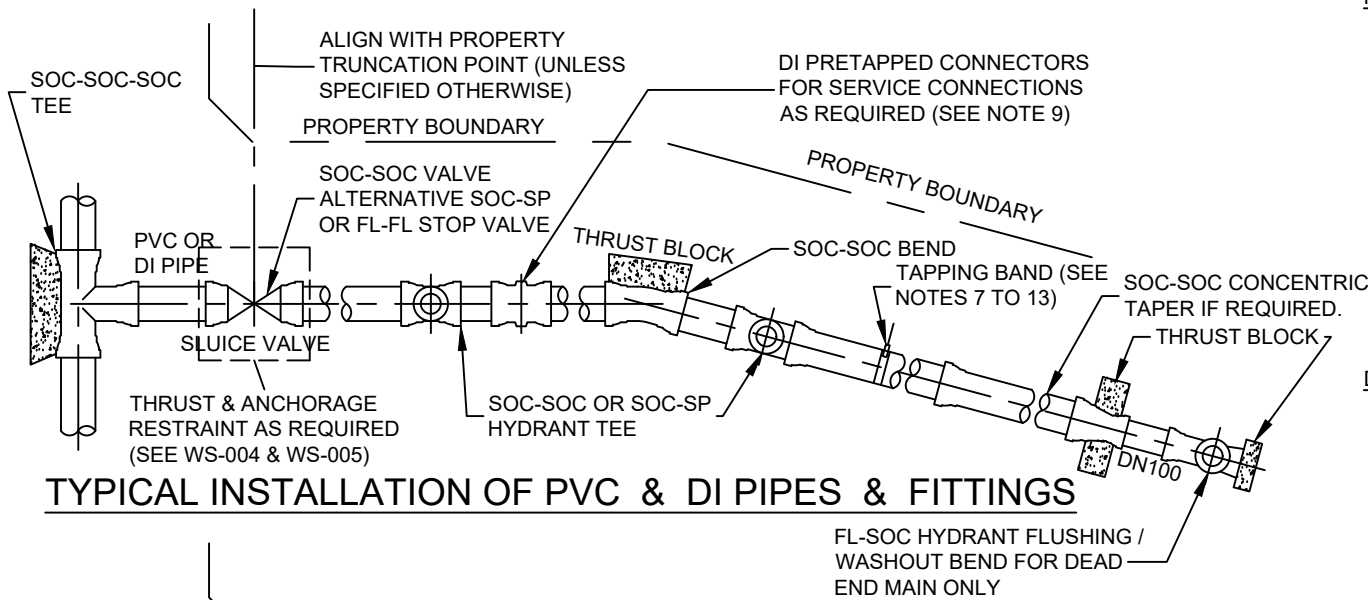

TYPICAL INSTALLATION OF PVC & DI PIPES & FITTINGS

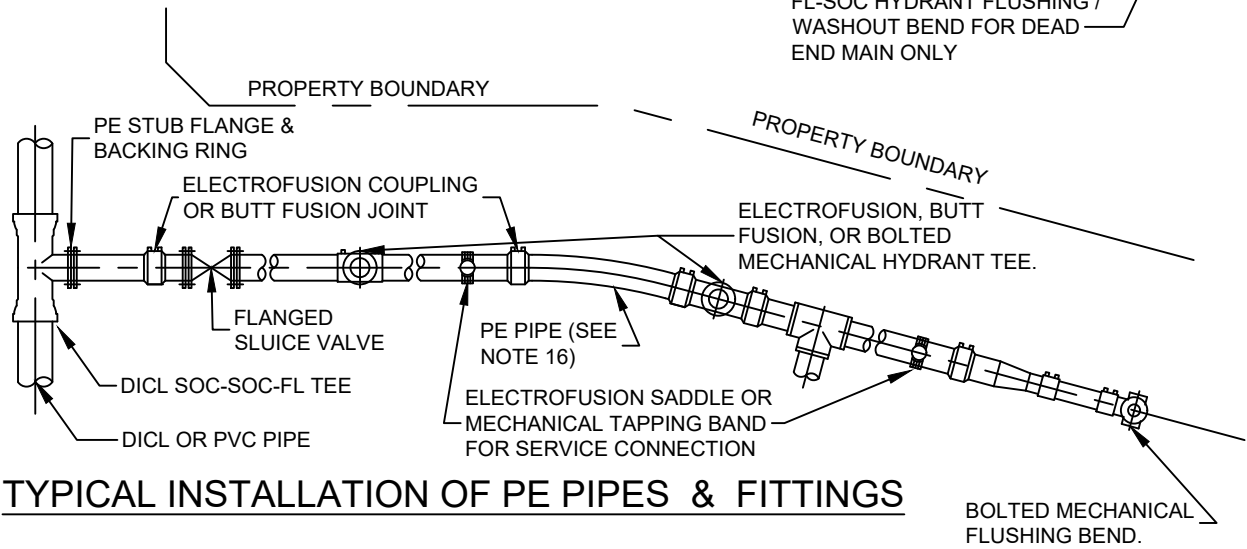

TYPICAL INSTALLATION OF PE PIPES & FITTINGS

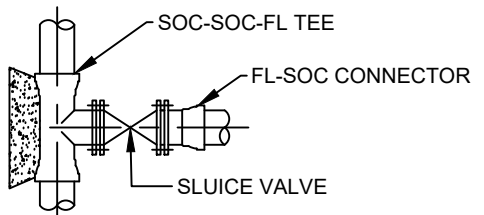

TYPICAL VALVE CONNECTION DIRECT TO NEW MAIN

NOTE:

1. ALL DIMENSIONS IN MILLIMETRES.
2. INSTALL PIPEWORK PARALLEL TO PROPERTY BOUNDARIES.
3. STAINLESS STEEL AND NYLON COATED (TO AS/NZS 4158) TAPPING BANDS DO NOT REQUIRE ADDITIONAL CORROSION PROTECTION.
4. WRAP BOLTED CONNECTIONS USING OTHER THAN NYLON COATED FITTINGS AND STAINLESS STEEL BOLTS WITH A PETROLATUM TAPE SYSTEM.
5. WHERE MAINS ARE 300 OR LARGER BYPASSES SHOULD BE INSTALLED FOR ALL MANUAL SLUICE VALVES.
6. ALL VALVES AND FITTINGS SHALL BE COATED WITH A THERMAL BONDED POLYMERIC COATING APPLIED IN ACCORDANCE WITH AS/NZS 4158.

DI & PVC PIPE

7. DUCTILE IRON FITTINGS MAY BE USED WITH DI & PVC PIPE.
8. FITTINGS SHALL BE NYLON COATED AND LINED OR CEMENT LINED WITH A BITUMINOUS EXTERNAL COATING. DO NOT USE PVC FITTINGS WITH DI PIPE.
9. USE PRE TAPPED CONNECTORS ON DN 100 & DN 150 NEW MAIN INSTALLATIONS (UNLESS SPECIFIED OTHERWISE BY THE TERRITORIAL AUTHORITY).
10. USE TAPPING BANDS FOR CONNECTIONS TO EXISTING MAINS AND NEW MAINS >DN 150.
11. ELECTRICALLY ISOLATE COPPER SERVICES FROM DI CL PIPE.

PVC PIPE

12. TAPPING BANDS ON PVC PIPE TO BE FULL CIRCLE CLAMPING.
13. WHERE PVC FITTINGS ARE USED, A PROTECTIVE MEMBRANE IS REQUIRED BETWEEN FITTING AND THRUST BLOCK. PVC FITTINGS TO BE USED ONLY ON PVC PIPE. DI SPIGOTS NOT TO BE INSERTED INTO PVC SOCKETS.
14. MAXIMUM SIZE OF DRILLED HOLES FOR SERVICE CONNECTIONS IN PVC PIPE TO BE 30% DN OR 50 (LOWER VALUE TO BE USED) LARGER HOLES CAN BE USED FOR UNDER PRESSURE TAPPING.

DI PIPE

15. DIRECT TAPPING OF >DN 200 DI CL MAY BE AUTHORISED BY TERRITORIAL AUTHORITY.

PE PIPE

16. PE PIPE MAY BE COLD BENT TO MINIMUM RADIUS OF 25 X (OD) STAKES OR OTHER SOURCES OF POINT LOADS SHALL NOT BE USED TO ASSIST IN BENDING THE PIPE.
17. MAKE ALLOWANCE DURING CONSTRUCTION FOR EXPANSION AND CONTRACTION OF PE PIPE DUE TO TEMPERATURE CHANGES.
18. BUTT WELDING IN ACCORDANCE WITH WSA-01 (POLYETHYLENE CODE) BUTT WELDING IN TRENCHES IS NOT PERMITTED.
19. ALL MECHANICAL COUPLINGS TO BE SELF-RESTRAINING.

<p>ORIGINAL SOURCE DRAWINGS: WATER SERVICES ASSOCIATION OF AUSTRALIA</p>	<p>NZS 4404:2010 LAND DEVELOPMENT AND SUBDIVISION INFRASTRUCTURE</p>	<p>NOT TO SCALE</p>
	<p>TYPICAL MAINS CONSTRUCTION - RETICULATION MAIN ARRANGEMENTS</p>	<p>WS-001</p>
		<p>B7-4</p>

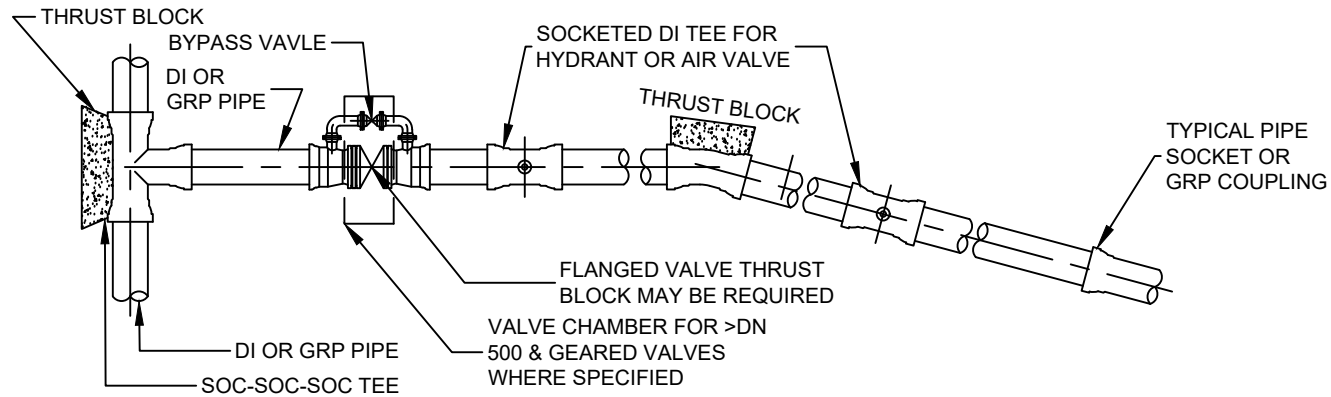

TYPICAL INSTALLATION OF DI AND GRP MAINS

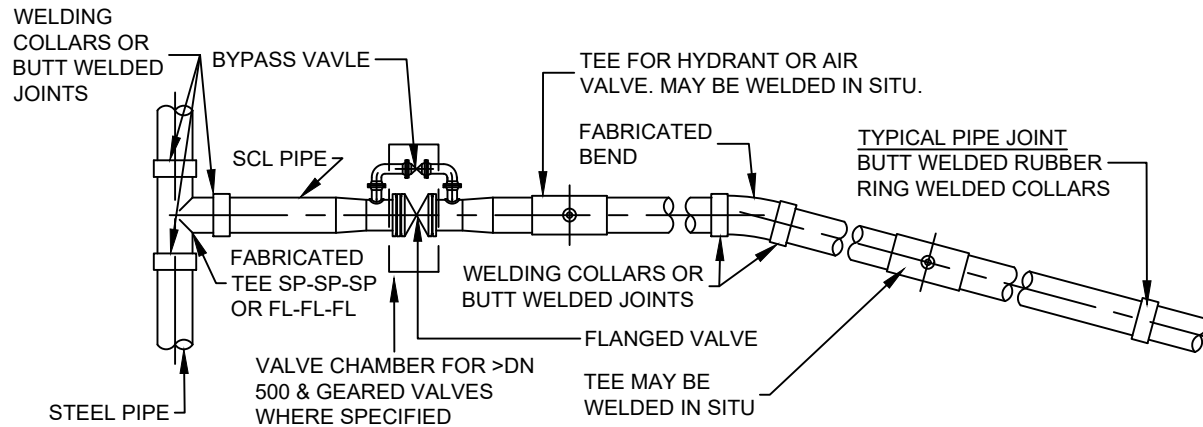

TYPICAL INSTALLATION OF STEEL MAINS

THRUST BLOCKS REQUIRED WHERE NON-RESTRAINING RUBBER RING JOINTS USED

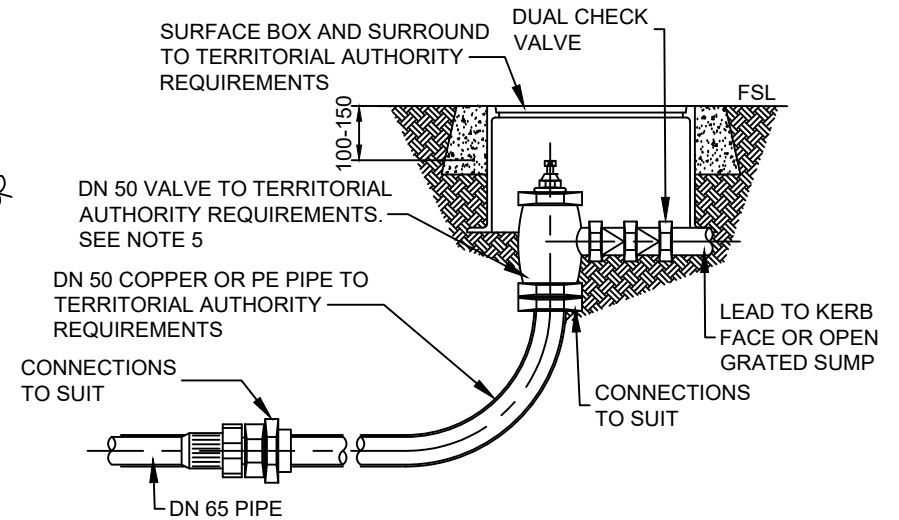

FLUSHING POINT

NOTES:

1. ALL DIMENSIONS IN MILLIMETRES.
2. WHERE POSSIBLE USE A SINGLE LENGTH OF PE PIPE.
3. THRUST BLOCKS TO BE IN ACCORDANCE WITH TERRITORIAL AUTHORITY REQUIREMENTS.
4. PVC PIPE MAY BE USED AS SHROUD PIPE, CUT AS REQUIRED TO CLEAR HYDRANT FLANGE.
5. FIT THE FLUSHING POINT VALVE IN SUCH A WAY AS TO PREVENT MOVEMENT OR ROTATION OF THE VALVE BODY. PROVIDE A SUITABLE PLUG OR CAP TO KEEP OUT DIRT AND GRAVEL.
6. PROVIDE CORROSION PROTECTION FOR ALL NON COATED METALLIC SURFACES IN ACCORDANCE WITH TERRITORIAL AUTHORITY REQUIREMENTS.
7. SERVICE CONNECTIONS NOT PERMITTED ON DISTRIBUTION MAINS WITHOUT TERRITORIAL AUTHORITY APPROVAL.



NZS 4404:2010
LAND DEVELOPMENT AND SUBDIVISION INFRASTRUCTURE

TYPICAL MAINS CONSTRUCTION -
DISTRIBUTION AND TRANSFER MAINS

NOT TO SCALE

WS-002

B7-5

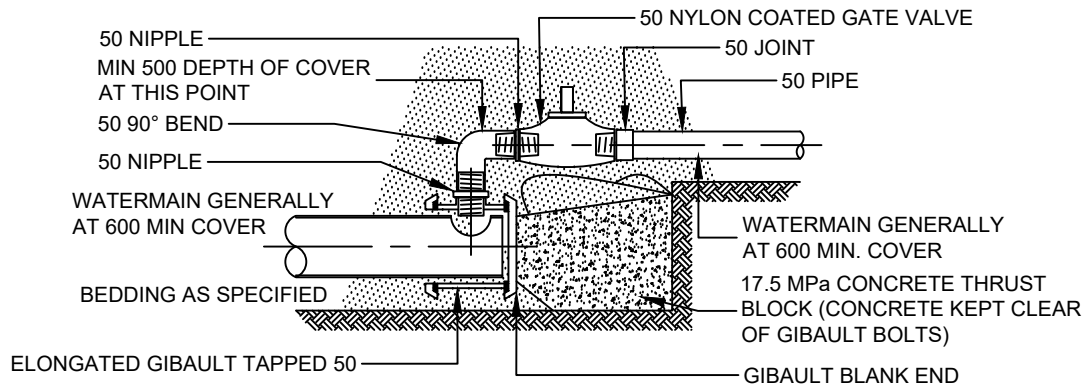

STRAIGHT LINE CONNECTION - METHOD 1 - ELEVATION

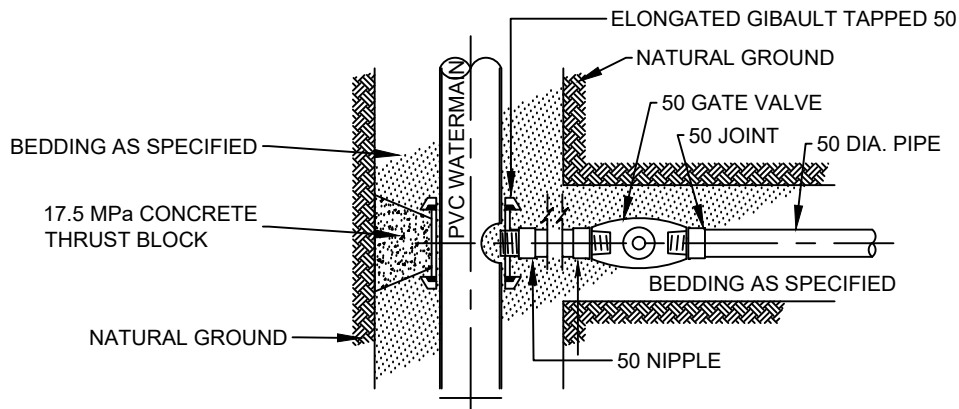

90° CONNECTION - PLAN RIDER MAIN CONNECTIONS

NOTE:

1. ALL DIMENSIONS IN MILLIMETRES.
2. USE METAL GATE VALVE ON 20 CONNECTIONS WHERE REQUIRED BY T.A. OR WHERE SHUTTING DOWN MAIN TO REPAIR SERVICE WOULD CAUSE SIGNIFICANT INTERRUPTION TO SUPPLY.
3. USE PROPRIETARY IN LINE METAL VALVES APPROVED BY T.A. WHEN MAIN IS TAPPED UNDER PRESSURE.
4. WHERE POSSIBLE, LAY SERVICE CONNECTIONS AND RIDER CONNECTIONS TO PRINCIPAL MAIN. WHERE NOT POSSIBLE INSTALL METALLIC TAPE ON TOP OF CONNECTION.
5. RIDER MAINS AND SERVICE CONNECTIONS TO PRINCIPAL MAIN USE ELONGATED GIBAULT, PROPRIETARY TEE (RIDER MAIN ONLY) OR APPROVED PROPRIETARY TAPPING BANDS.

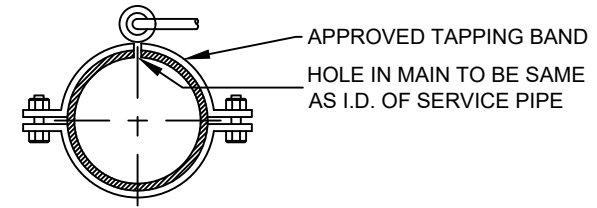

SECTION A

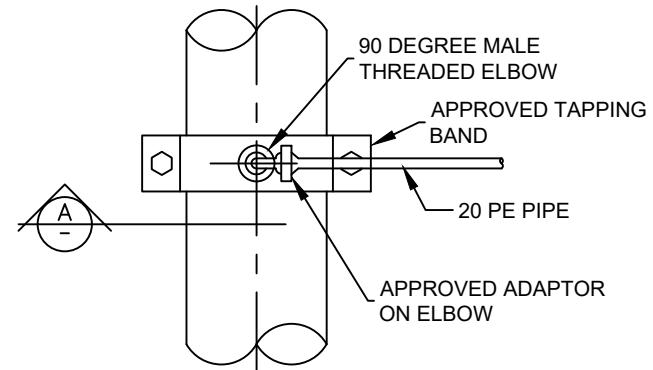

PLAN

STANDARD TAPPING METHODS

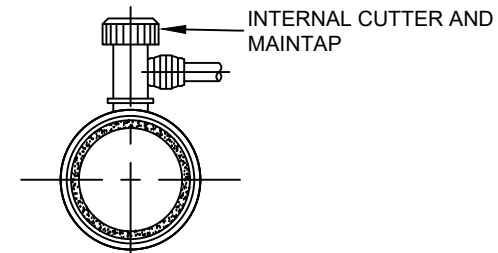

ELECTROFUSION TAPPING SADDLE PE PIPE

 ORIGINAL SOURCE DRAWINGS: WATER SERVICES ASSOCIATION OF AUSTRALIA	NZS 4404:2010 LAND DEVELOPMENT AND SUBDIVISION INFRASTRUCTURE	NOT TO SCALE		
	PROPERTY SERVICES - CONNECTION TO AN EXISTING PVC MAIN		WS-003	
			B7-6	

MINIMUM BLOCK VOLUME FOR ANCHORAGE

VERTICAL BENDS
FOR TEST PRESSURE OF 1000kPa (SEE NOTE 2)

PIPE DN	CONCRETE VOLUME M ³		
	11.25° BEND	22.25° BEND	45° BEND
100	N	N	0.3
150	N	0.3	0.6
200	0.2	0.5	1.1
225	0.3	0.6	1.4
250	0.3	0.7	2.5
300	0.4	1.1	3.8
375	0.7	1.8	5.8
450	DETAILED DESIGN REQUIRED (ALTERNATIVE METHODS TO BE CONSIDERED)		
500			
600			
750			

'N' - NO ADDITIONAL RESTRAINT REQUIRED
(COMPACTED TRENCHFILL SUFFICIENT)

ANCHOR BLOCK CONSTRUCTION NOTES:

- LOCATE ANCHOR BLOCK CENTRALLY AROUND BEND.
- KEY ANCHOR BLOCK INTO BASE OF TRENCH A MINIMUM DEPTH OF 250.
- POUR CONCRETE AGAINST A SOLID EXCAVATION FACE.
- USE GRADE 17.5 MPa CONCRETE.
- KEEP CONCRETE CLEAR OF ALL BOLTS, NUTS, AND PIPE JOINTS.

NOTE:

1. ALL DIMENSIONS IN MILLIMETRES, UNLESS SHOWN OTHERWISE.
2. ANCHOR BLOCKS IN THE TABLE ARE DESIGNED FOR A TEST PRESSURE OF 1000 kPa (100 m HEAD) ADJUST CONCRETE VOLUME TO SUIT ACTUAL TEST PRESSURE.
3. WHERE DI PIPES AND FITTINGS WITH RESTRAINED JOINTS ARE USED THRUST BLOCKS ARE NOT REQUIRED.
4. THRUST BLOCK REINFORCEMENT AS SPECIFIED IN DESIGN DRAWINGS.
5. WHERE SPECIFIED PROVIDE CONCRETE THRUST BLOCKS FOR SOC-SOC VALVES. THRUST AREA TO BE AS FOR DEAD ENDS AS SHOWN IN WS-004.
6. INSTALL PUDDLE FLANGES ON CLASS K12 DICL PIPE.

THRUST IN BOTH DIRECTIONS
USE PUDDLE FLANGE PIPE
LENGTH TO SUIT
SEE NOTE 6

THRUST IN ONE DIRECTION
LOCATE THRUST BLOCK
AGAINST SOCKET.

FLOW
THRUST IN ONE
DIRECTION

THRUST AREA
BASE AND WALLS
SEE NOTE 5

FLANGED VALVES

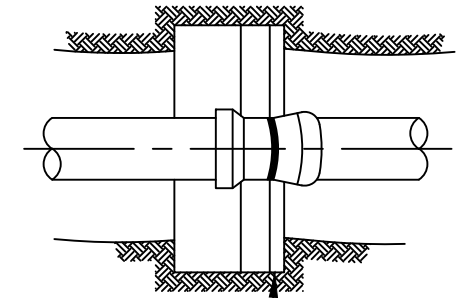
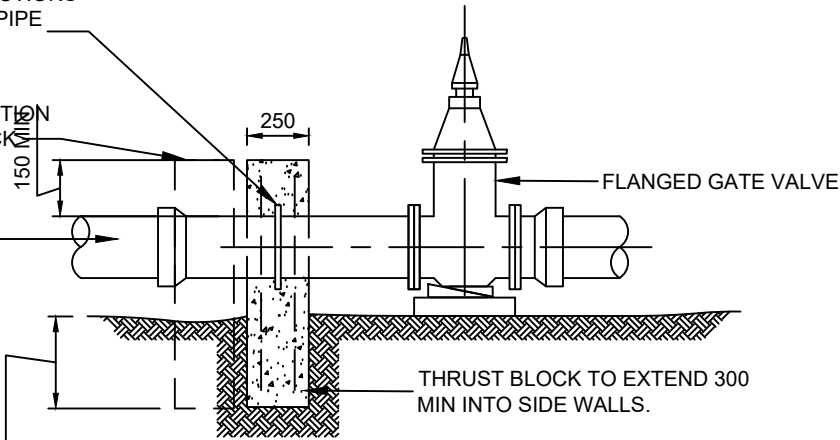

ANCHOR CLOCK MINIMUM
VOLUME AS PER TABLE
SEE NOTE 2

PLAN

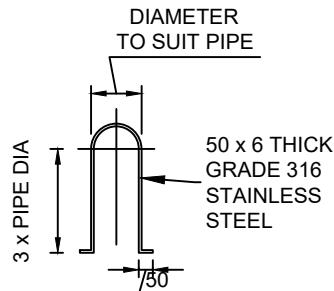

TYPICAL SS STRAP

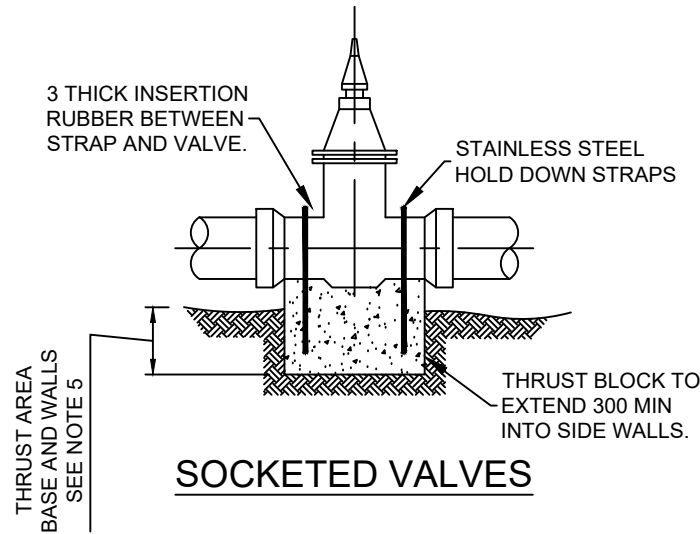

SOCKETED VALVES

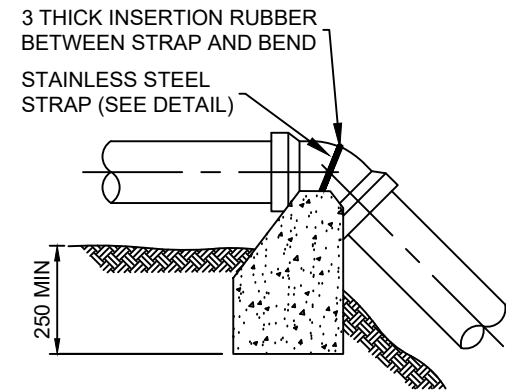

ELEVATION VERTICAL BENDS



NZS 4404:2010
LAND DEVELOPMENT AND SUBDIVISION INFRASTRUCTURE

**THRUST AND ANCHOR BLOCKS - GATE
VALVES AND VERTICAL BENDS IF REQUIRED**

NOT TO SCALE

WS-005

B7-7

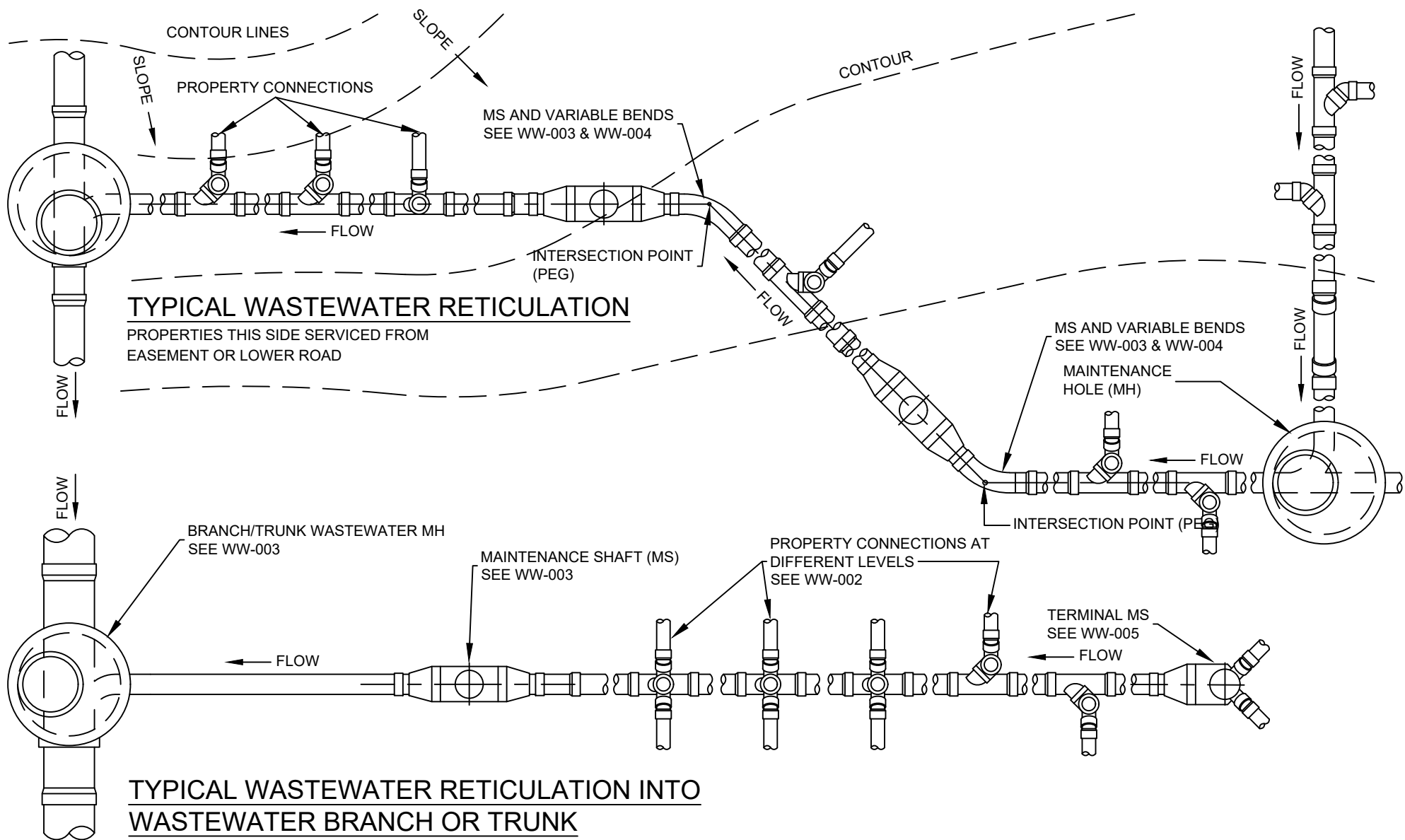

- NOTE:
1. GRADE WASTEWATER EVENLY BETWEEN MH/MS TO LEVELS SHOWN IN DESIGN DRAWINGS.
 2. LAY PIPES AND FITTINGS WITH SOCKETS UPSTREAM WHEREVER PRACTICABLE.



NZS 4404:2010 LAND DEVELOPMENT AND SUBDIVISION INFRASTRUCTURE		NOT TO SCALE	
PIPELAYING - TYPICAL ARRANGEMENTS		WW-001	
		B7-8	

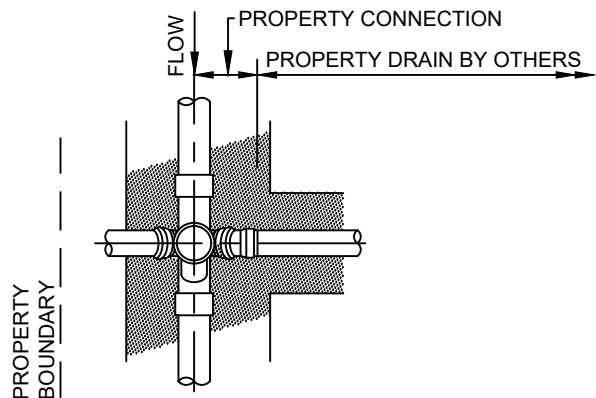

PLAN
WASTEWATER WITHIN PROPERTY

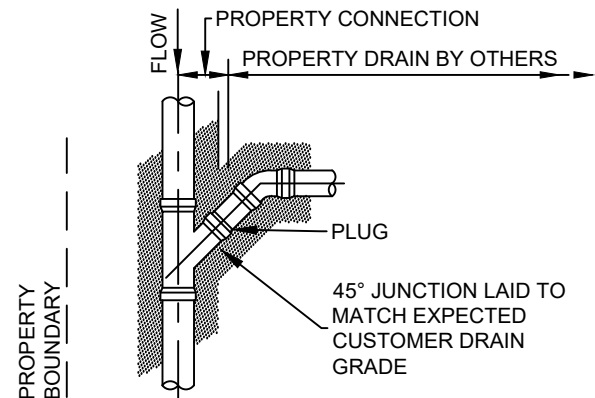

PLAN
WASTEWATER WITHIN PROPERTY

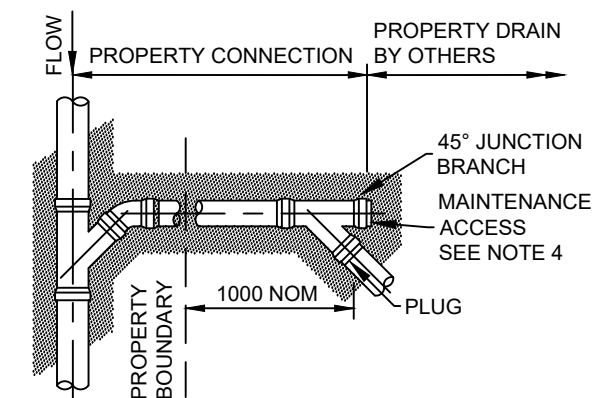

PLAN
WASTEWATER WITHIN PROPERTY

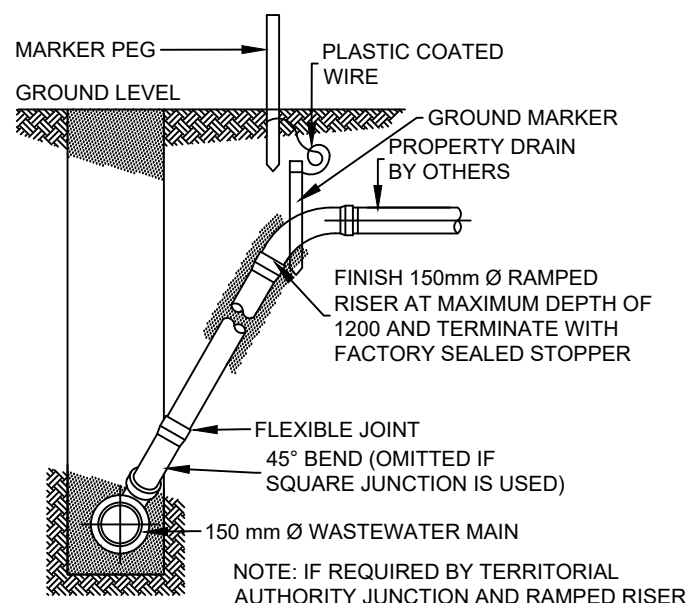

NOTE: IF REQUIRED BY TERRITORIAL AUTHORITY JUNCTION AND RAMPED RISER TO BE SURROUNDED BY MIN 150 mm THICKNESS OF 17.5 MPa CONCRETE DISCONTINUOUS AT PIPE JOINTS.

ELEVATION
Y JUNCTION RAMPED RISERS

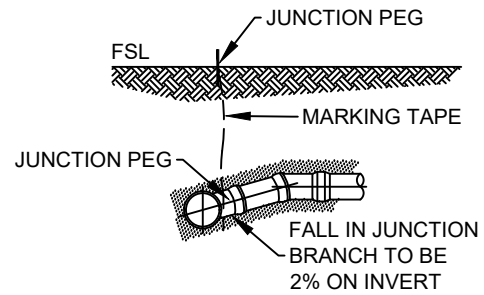

ELEVATION
STANDARD CONNECTION

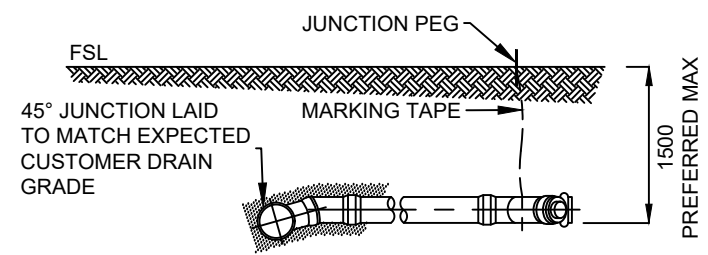

ELEVATION
EXTENDED CONNECTION
MAY ALSO BE INSTALLED AS A SLOPED CONNECTION

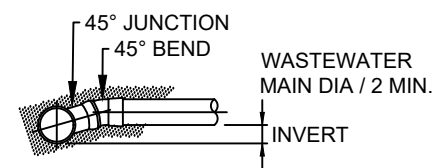

MINIMUM LEVEL
STANDARD CONNECTION

- NOTE:
1. ALL DIMENSIONS IN MILLIMETRES.
 2. ALL CONNECTION TYPES SHOWN IN THIS DRAWING ARE APPLICABLE TO VC, PVC.
 3. LAY PROPERTY DRAIN CONNECTION AT DEPTH AS SHOWN IN DESIGN DRAWINGS.
 4. PROVIDE RODDING POINTS WHERE REQUIRED BY TERRITORIAL AUTHORITY.
 5. GRADE OF PROPERTY CONNECTION WASTEWATER PIPE TO BE NOT LESS THAN:

DN 100	1.65%
DN 150	1.2%

 <small>ORIGINAL SOURCE DRAWINGS: WATER SERVICES ASSOCIATION OF AUSTRALIA</small>	<small>NZS 4404:2010 LAND DEVELOPMENT AND SUBDIVISION INFRASTRUCTURE</small>	NOT TO SCALE		
	PROPERTY CONNECTION - BURIED INTERFACE METHOD		WW-002	
			B7-9	

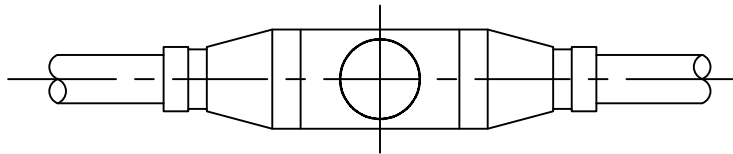

PLAN

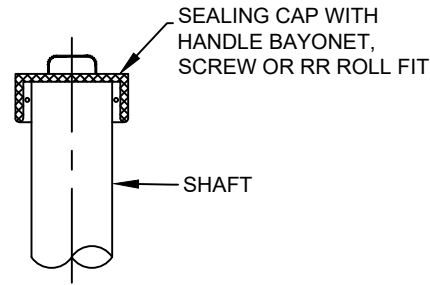

RISER SHAFT CAP

NOTE:

1. ALL DIMENSIONS IN MILLIMETRES.
2. MS MAY BE MANUFACTURED USING VARIOUS MATERIALS AND JOINTING SYSTEMS AS AUTHORISED BY TERRITORIAL AUTHORITY.
3. MAXIMUM DEPTH TO INVERT 3000.
4. ADJUST MS TO PIPE GRADE BY TILTING MS CHAMBER. MAX DEVIATION FROM VERTICAL OF THE RISER TO BE 1:10 OR A MAXIMUM OF 300 AT SURFACE. USE KICKER BEND IF REQUIRED TO ADJUST RISER TO VERTICAL.
5. ACCESS COVER, FRAME, AND SUPPORT SLAB TO BE AS AUTHORISED BY TERRITORIAL AUTHORITY.

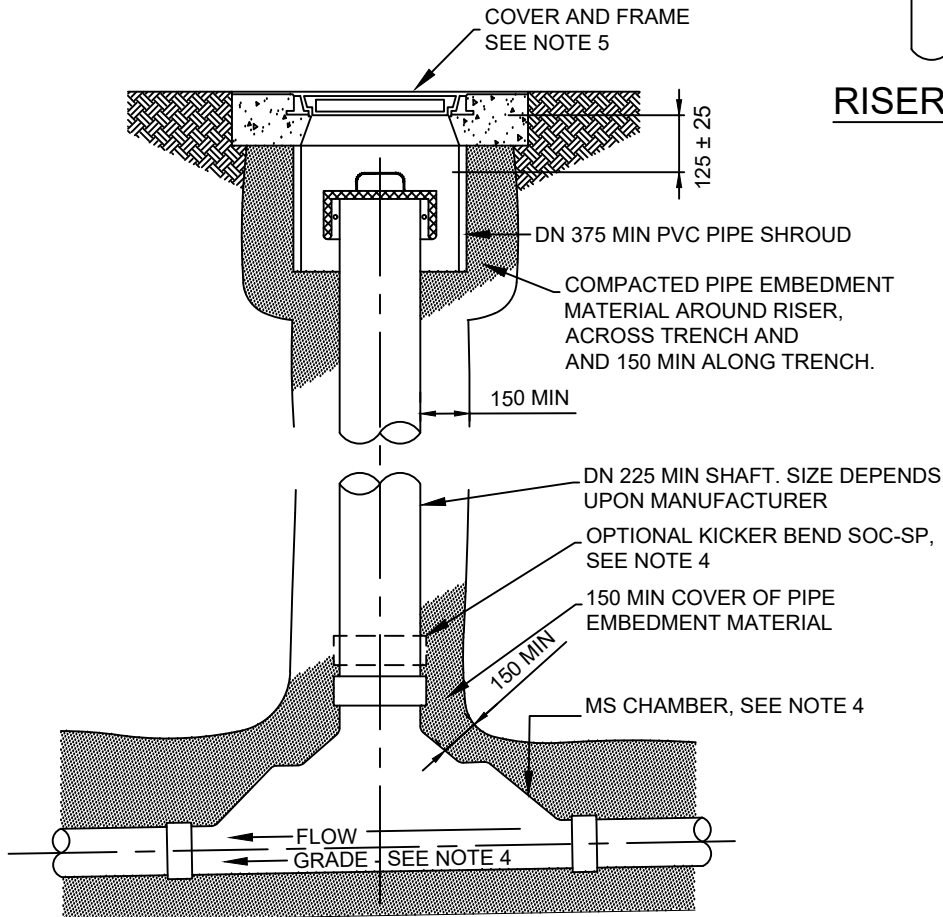

**END ELEVATION
MAINTENANCE SHAFT**

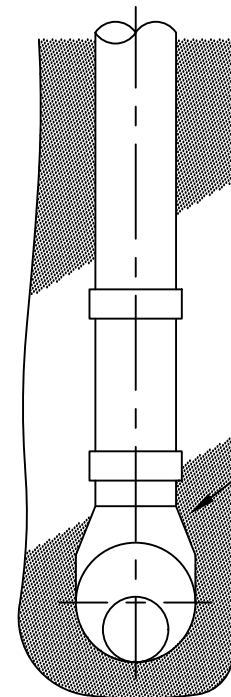

**END ELEVATION
PLAIN RISER SHAFT**

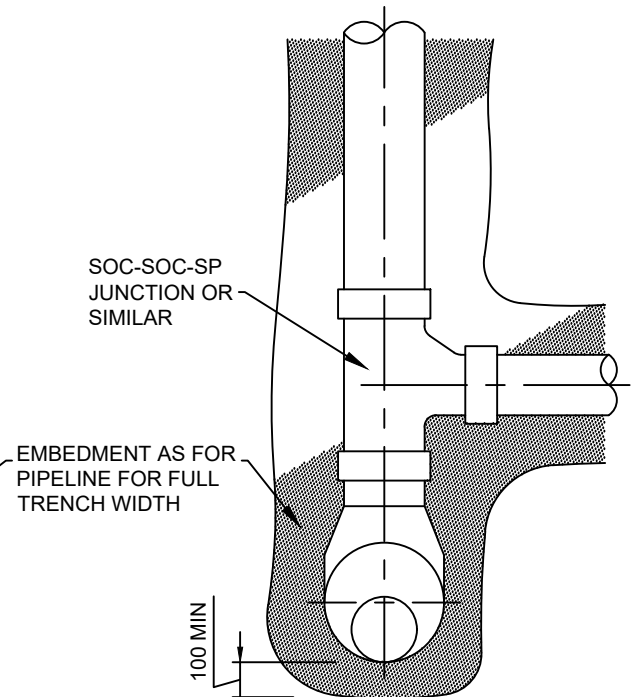

**END ELEVATION
DROP JUNCTION**

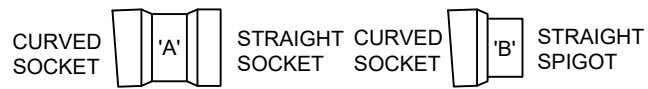

LEGEND

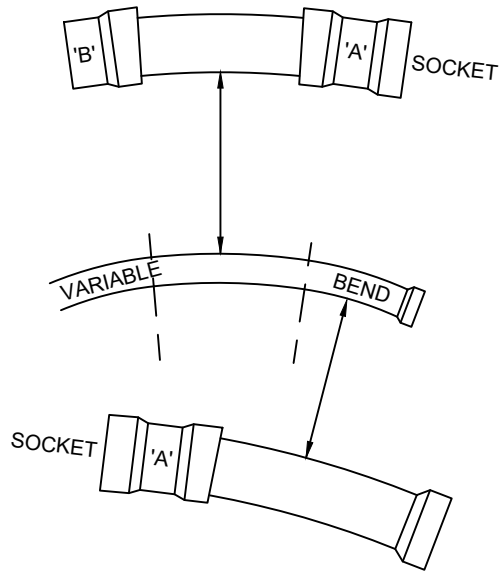

TYPICAL VARIABLE BENDS

ALL COMBINATIONS OF ENDS ACCEPTED

NOTE:

1. ALL DIMENSIONS IN MILLIMETRES.
2. VARIABLE BEND CUT TO LENGTH TO ACHIEVE REQUIRED DEFLECTION.
3. RECORD DETAILS OF BEND LOCATIONS AND ANGLES ON WORK AS CONSTRUCTED DRAWINGS.

SHORT RADIUS VARIABLE BEND
CUT TO SUIT CHANGE IN PROFILE
INTERSECTION POINT (PEG)

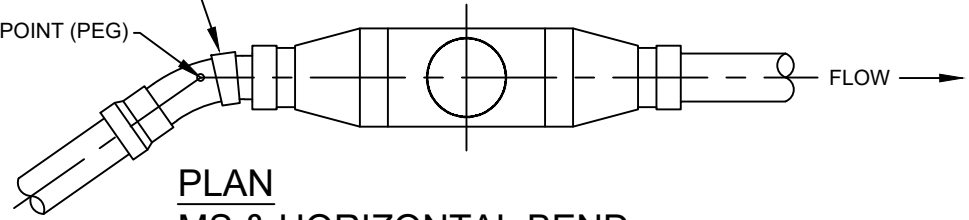

**PLAN
MS & HORIZONTAL BEND**

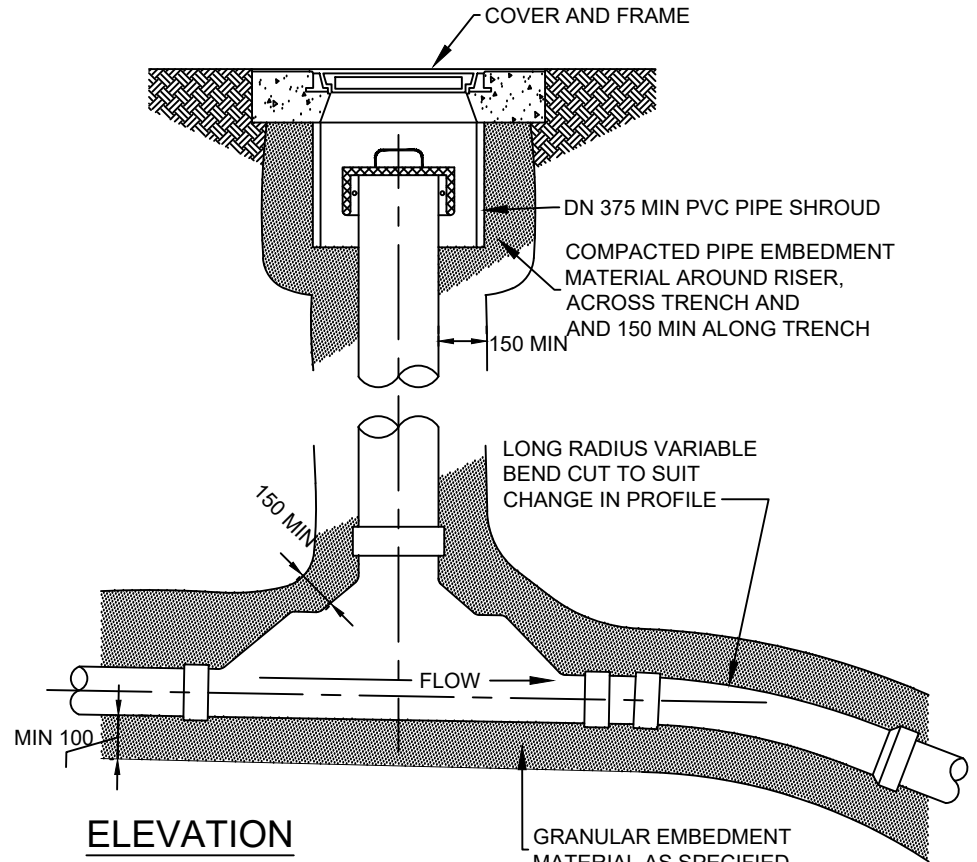

**ELEVATION
MS & VERTICAL BEND**

<p>STANDARDS NEW ZEALAND PAKĀREVA AOTEAROA</p> <p><small>ORIGINAL SOURCE DRAWINGS: WATER SERVICES ASSOCIATION OF AUSTRALIA</small></p>	<p>NZS 4404:2010 LAND DEVELOPMENT AND SUBDIVISION INFRASTRUCTURE</p>	<p>NOT TO SCALE</p>		
	<p>MAINTENANCE SHAFTS - MS AND VARIABLE BEND INSTALLATIONS</p>		<p>WW-004</p>	
			<p>B7-11</p>	

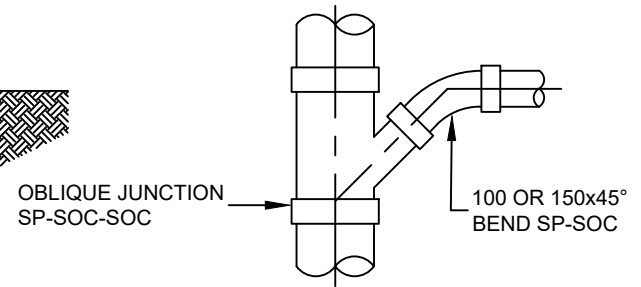
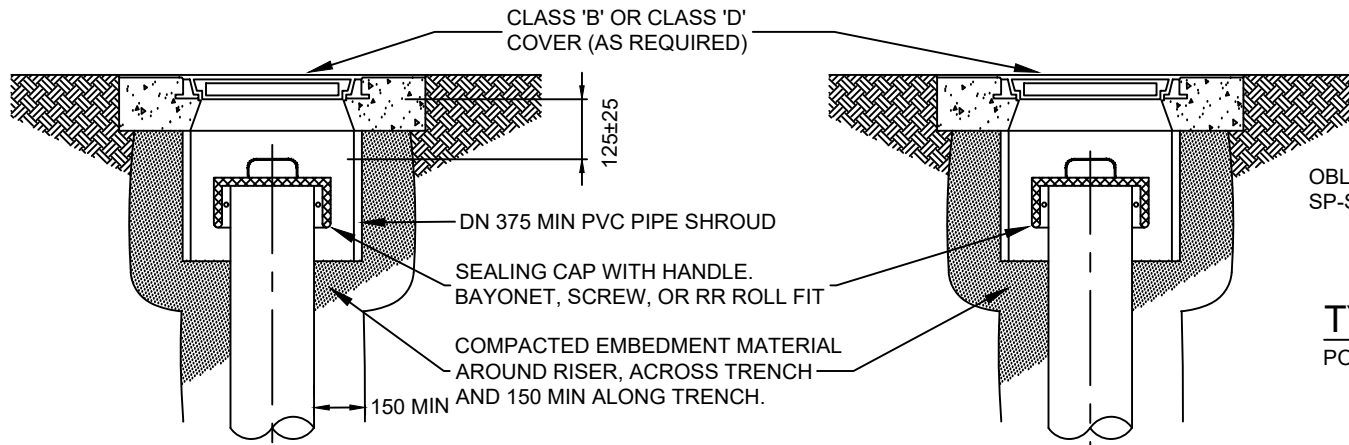

TYPICAL PROPERTY CONNECTIONS
POSITIONED IN RISER AS SPECIFIED

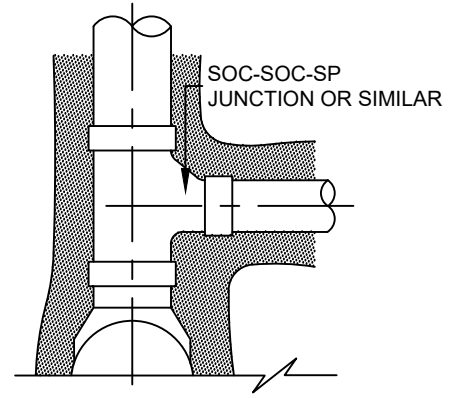

DN 150 RETICULATION INLETS
POSITIONED IN RISER AS SPECIFIED

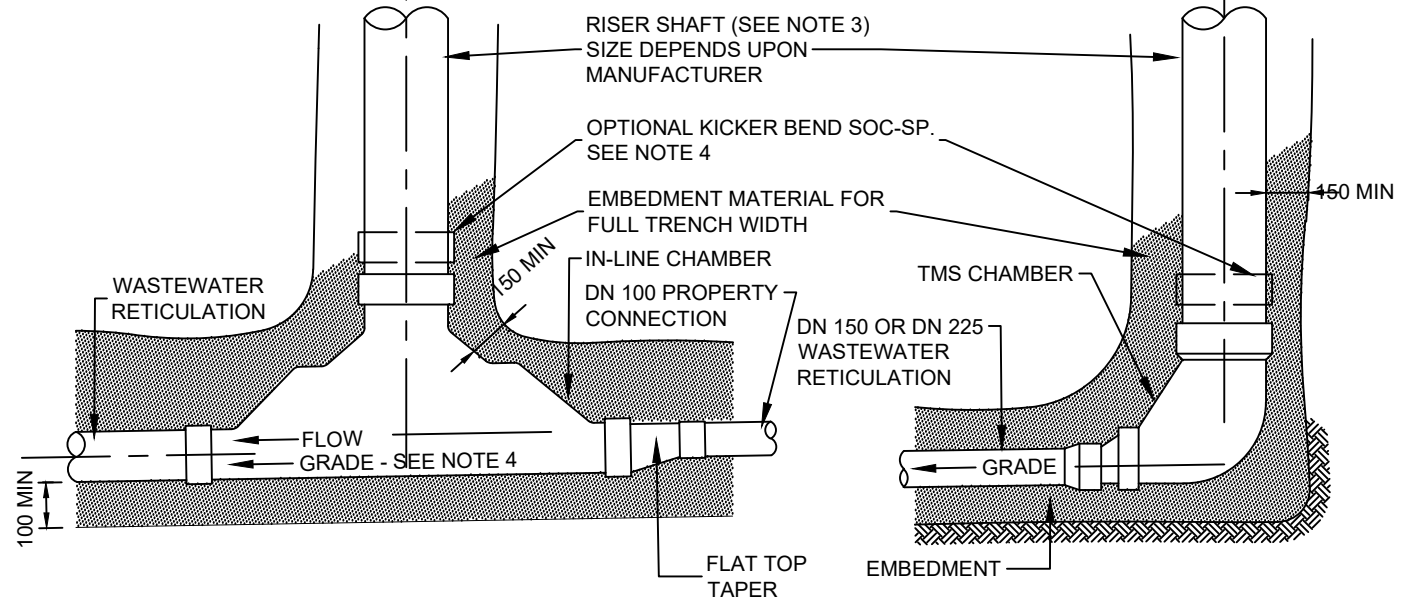

ELEVATION
TERMINAL MAINTENANCE SHAFT WITH
PROPERTY CONNECTION AHEAD

ELEVATION
TERMINAL MAINTENANCE SHAFT

NOTE:

1. ALL DIMENSIONS IN MILLIMETRES.
2. ALL CONNECTION TYPES SHOWN ARE APPLICABLE TO VC, PVC (SOLVENT WELD) AND PVC (RUBBER RING) PIPES UNLESS OTHERWISE SHOWN.
3. INSTALL BRANCH CONNECTIONS AND PROPERTY CONNECTIONS (AS SHOWN ABOVE) IN RISER SHAFT (DROP JUNCTIONS) WHERE SHOWN IN DESIGN DRAWINGS. MAXIMUM OF 1 RETICULATION INLET OR 2 PROPERTY CONNECTIONS.
4. ADJUST MS TO PIPE GRADE BY TILTING CHAMBER. MAX DEVIATION FROM VERTICAL OF THE RISER TO BE 1:10 OR A MAXIMUM OF 300 AT SURFACE. USE KICKER BEND IF REQUIRED TO ADJUST RISER TO VERTICAL.



NZS 4404:2010
LAND DEVELOPMENT AND SUBDIVISION INFRASTRUCTURE

MAINTENANCE SHAFTS - TMS AND
CONNECTION INSTALLATION

NOT TO SCALE

WW-005

B7-12